

Features:

- Supports 8.5Gb/s to 11.3Gb/s bit rates
- Hot-pluggable SFP+ footprint
- Single LC for Bi-directional Transmission
- Maximum link length of 60km
- Built-in 1330 WDM Filter
- Built-in 1330nm CWDM DFB Laser.
- Power dissipation <1.5W
- No Reference Clock required
- Built-in digital diagnostic functions
- Temperature range 0°C to 70°C
- Very low EMI and excellent ESD protection
- RoHS Compliant



Applications:

- 10GBASE-LR/LW Ethernet
- 10G Fibre Channel
- SONET OC-192/SDH STM-64

Description:

NBP-3327192-06CD Bi-directional 10Gb/s (SFP+) transceivers are compliant with the current SFP+ Multi-Source Agreement (MSA) Specification. They comply with 10GBASE-LR/LW Ethernet, SONET OC-192/SDH STM-64 and 10G Fibre Channel 1200-SM-LL-L. Digital diagnostics functions are available via a 2-wire serial interface, as specified in the SFP+ MSA.

Specification:

Absolute Maximum Ratings

Parameter	Symbol	Min.	Typical	Max.	Unit
Storage Temperature	T_S	-40		+85	°C
Supply Voltage	$V_{CC,T,R}$	-0.5		4	V
Relative Humidity	RH	0		85	%

Recommended Operating Environment:

Parameter	Symbol	Min.	Typical	Max.	Unit
Case operating Temperature	T_C	0		+70	°C
Supply Voltage	$V_{CC,T,R}$	+3.13		+3.47	V
Supply Current	I_{CC}			380	mA
Power Dissipation	P_D			1.5	W

Electrical Characteristics ($T_{OP} = T_c$, $V_{CC} = 3.135$ to 3.465 Volts)

Parameter	Symbol	Min	Typ	Max	Unit	Note	
Transmitter:							
Differential input voltage swing		18		700	mVpp	1	
Transmit Disable Input	H	V_{IH}	2.0		$V_{CC}+0.3$	V	
	L	V_{IL}	0		0.8	V	
Transmit Enable Output	H	V_{OH}	2.4		$V_{CC}+0.3$	V	
	L	V_{OL}	0		0.4	V	2
Input Differential Impedance	Z_{in}	80	100	120	Ω		
Receiver							
Differential output voltage swing		300		850	mVpp	3	
LOS Output	H	V_{OH}	2.4		$V_{CC}+0.3$	V	2
	L	V_{OL}	0		0.4	V	
Output Differential Impedance	Z_{on}	80	100	120	Ω		

Notes:

Note 1) TD+/- are internally AC coupled with 100 Ω differential termination inside the module.

Note 2) Tx Fault and Rx LOS are open collector outputs, which should be pulled up with 4.7k to 10k Ω resistors on the host board. Pull up voltage between 2.0V and $V_{CC}+0.3V$.

Note 3) RD+/- outputs are internally AC coupled, and should be terminated with 100 Ω (differential) at the user SERDES.

Optical Characteristics ($T_{OP} = T_c$, $V_{CC} = 3.135$ to 3.465 Volts)

Parameter	Symbol	Min	Typ	Max	Unit	Ref.
Transmitter						
Date Rate		8.5		11.3	Gb/s	
Optical Wavelength	λ	1320	1330	1340	nm	
Average output power	P_o	+1		+5	dBm	
Optical Extinction Ratio	ER	3.5			dB	
RMS spectral width	$\Delta\lambda$			1	nm	
Side Mode Suppression Ratio	SMSR	30			dB	
Optical Eye Mask		Compliant with IEEE802.3ae				
Receiver						
Date Rate		8.5		11.3	Gb/s	
Optical Wavelength	λ	1260	1270	1280	nm	
Receiver Sensitivity@10G	R			-20	dBm	1
Maximum Input Power	P _{MAX}	-3			dBm	
LOS De-Assert	LOSD			-21	dBm	
LOS Assert	LOSA	-33			dBm	
LOS Hysteresis		0.5		4	dB	

Notes:

1. Measured with a PRBS of $2^{31}-1$ at 1×10^{-12} BER and 3.5 dB extinction ratio.

Pin Assignment:

Diagram of Host Board Connector Block Pin Numbers and Name

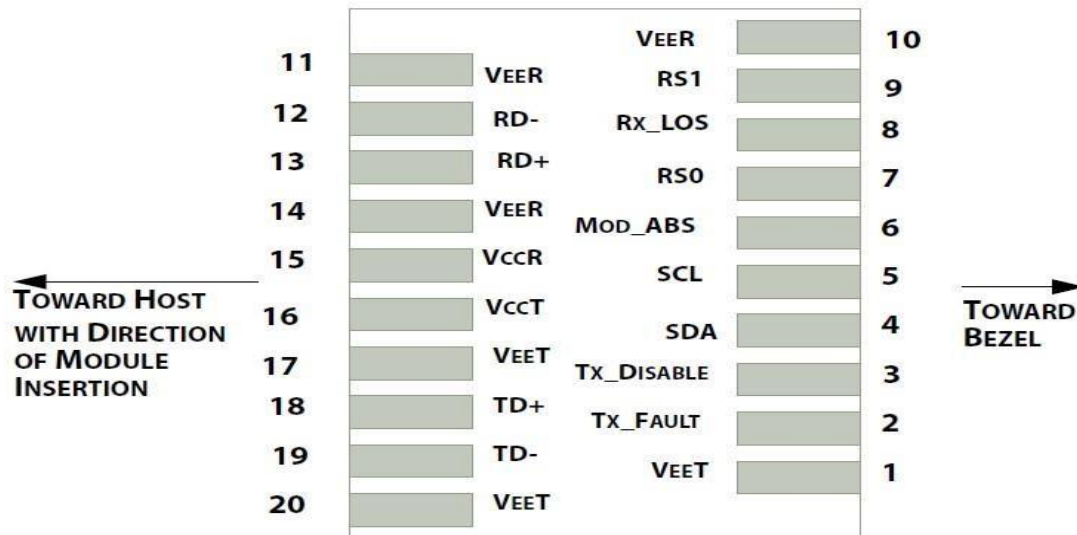

Pin Function Definitions

PIN #	Name	Function	Notes
1	VeeT	Module transmitter ground	1
2	Tx Fault	Module transmitter fault	2
3	Tx Disable	Transmitter Disable; Turns off transmitter laser output	3
4	SDL	2 wire serial interface data input/output (SDA)	
5	SCL	2 wire serial interface clock input (SCL)	
6	MOD-ABS	Module Absent, connect to VeeR or VeeT in the module	2
7	RS0	Rate select0, optionally control SFP+ receiver. When high, input data rate >4.5Gb/s; when low, input data rate <=4.5Gb/s	
8	LOS	Receiver Loss of Signal Indication	4
9	RS1	Rate select0, optionally control SFP+ transmitter. When high, input data rate >4.5Gb/s; when low, input data rate <=4.5Gb/s	
10	VeeR	Module receiver ground	1
11	VeeR	Module receiver ground	1
12	RD-	Receiver inverted data out put	
13	RD+	Receiver non-inverted data out put	
14	VeeR	Module receiver ground	1
15	VccR	Module receiver 3.3V supply	
16	VccT	Module transmitter 3.3V supply	
17	VeeT	Module transmitter ground	1
18	TD+	Transmitter inverted data out put	
19	TD-	Transmitter non-inverted data out put	
20	VeeT	Module transmitter ground	1

Notes:

Note 1) The module ground pins shall be isolated from the module case.

Note 2) This pin is an open collector/drain output pin and shall be pulled up with 4.7K-10Kohms to Host_Vcc on the host board.

Note 3) This pin shall be pulled up with 4.7K-10Kohms to VccT in the module.

Note 4) This pin is an open collector/drain output pin and shall be pulled up with 4.7K-10Kohms to Host_Vcc on the host board.

SFP Module EEPROM Information and Management

The SFP+ modules implement the 2-wire serial communication protocol as defined in the SFF-8472. The serial ID information of the SFP modules and Digital Diagnostic Monitor parameters can be accessed through the I2C interface at address A0h and A2h.

The memory is mapped in Table 1.

Detailed ID information(A0h) is listed in Table 2. And the DDM specification is at address A2h.

For more details of the memory map and byte definitions, please refer to the SFF-8472, “Digital Diagnostic Monitoring Interface for Optical Transceivers”. The DDM parameters have been internally calibrated.

Table 1. Digital Diagnostic Memory Map (Specific Data Field Descriptions)

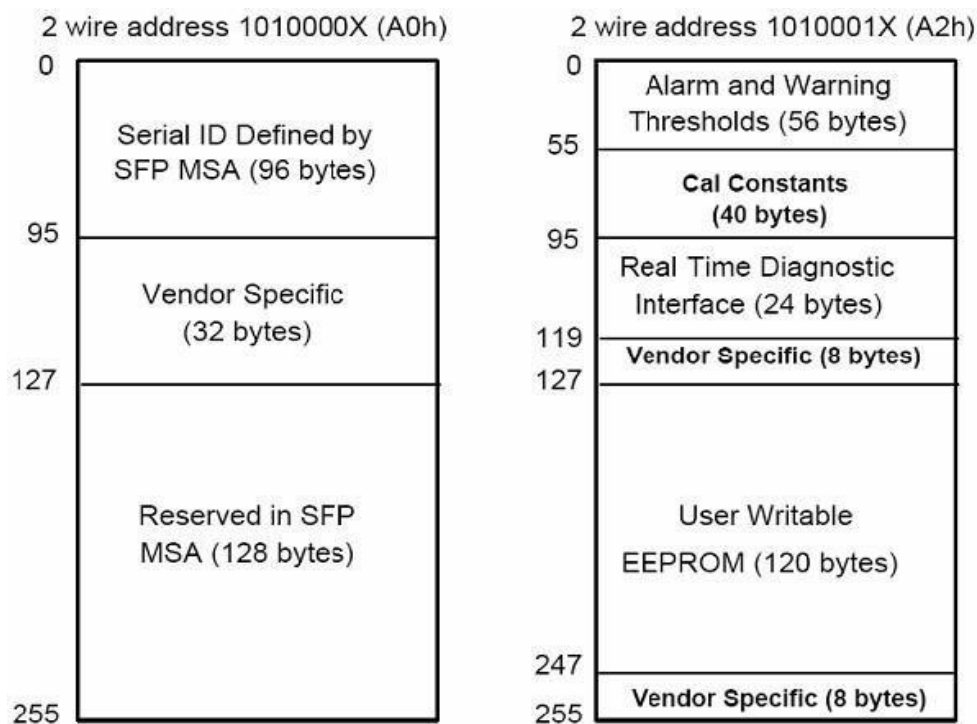

Table 2 - EEPROM Serial ID Memory Contents (A0h)

Data Address	Length (Byte)	Name of Length	Description and Contents
Base ID Fields			
0	1	Identifier	Type of Serial transceiver (03h=SFP)
1	1	Reserved	Extended identifier of type serial transceiver (04h)
2	1	Connector	Code of optical connector type (07=LC)
3-10	8	Transceiver	10G Base-ER
11	1	Encoding	64B/66B
12	1	BR, Nominal	Nominal baud rate, unit of 100Mbps
13-14	2	Reserved	(0000h)
15	1	Length(9um)	Link length supported for 9/125um fiber, units of 100m
16	1	Length(50um)	Link length supported for 50/125um fiber, units of 10m
17	1	Length(62.5um)	Link length supported for 62.5/125um fiber, units of 10m
18	1	Length(Copper)	Link length supported for copper, units of meters
19	1	Reserved	
20-35	16	Vendor Name	SFP vendor name

36	1	Reserved	
37-39	3	Vendor OUI	SFP transceiver vendor OUI ID
40-55	16	Vendor PN	Part Number: "xxx" (ASCII)
56-59	4	Vendor rev	Revision level for part number
60-62	3	Reserved	
63	1	CCID	Least significant byte of sum of data in address 0-62
Extended ID Fields			
64-65	2	Option	Indicates which optical SFP signals are implemented (001Ah = LOS, TX_FAULT, TX_DISABLE all supported)
66	1	BR, max	Upper bit rate margin, units of %
67	1	BR, min	Lower bit rate margin, units of %
68-83	16	Vendor SN	Serial number (ASCII)
84-91	8	Date code	Manufacturing date code
92-94	3	Reserved	
95	1	CCEX	Check code for the extended ID Fields (addresses 64 to 94)
Vendor Specific ID Fields			
96-127	32	Readable	specific date, read only
128-255	128	Reserved	Reserved for SFF-8079

Digital Diagnostic Monitor Characteristics

Data Address	Parameter	Accuracy	Unit
96-97	Transceiver Internal Temperature	±3.0	°C
98-99	VCC3 Internal Supply Voltage	±5.0	%
100-101	Laser Bias Current	±10	%
102-103	Tx Output Power	±3.0	dBm
104-105	Rx Input Power	±3.0	dBm

Regulatory Compliance

The NBP-3327192-06CD complies with international Electromagnetic Compatibility (EMC) and international safety requirements and standards (see details in Table following).

Electrostatic Discharge (ESD) to the Electrical Pins	MIL-STD-883E Method 3015.7	Class 1(>1000 V)
Electrostatic Discharge (ESD) to the Duplex LC Receptacle	IEC 61000-4-2 GR-1089-CORE	Compatible with standards
Electromagnetic Interference (EMI)	FCC Part 15 Class B EN55022 Class B (CISPR 22B) VCCI Class B	Compatible with standards
Laser Eye Safety	FDA 21CFR 1040.10 and 1040.11 EN60950, EN (IEC) 60825-1,2	Compatible with Class 1 laser product.

Recommended Circuit:

Recommended Host Board Power Supply Circuit

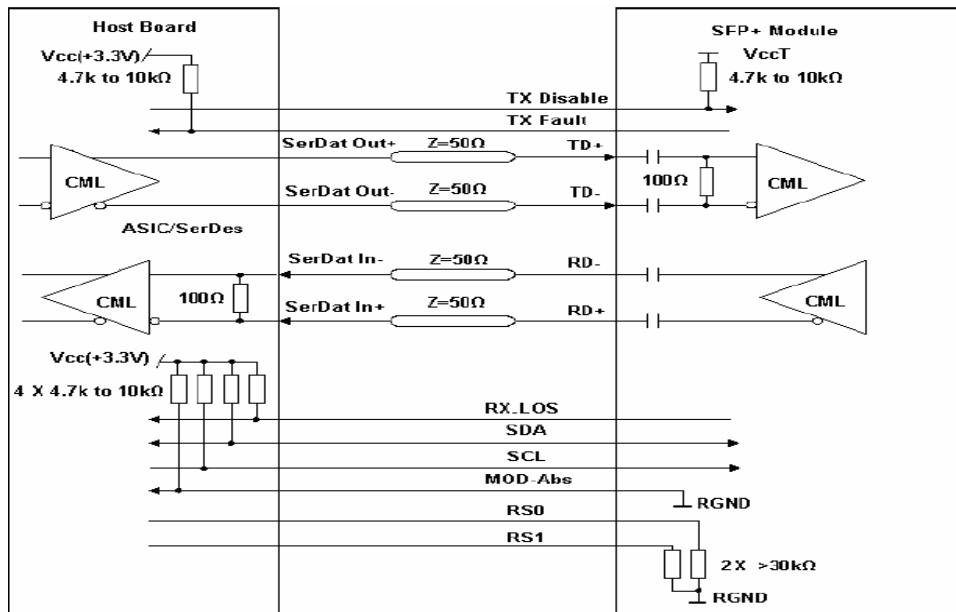
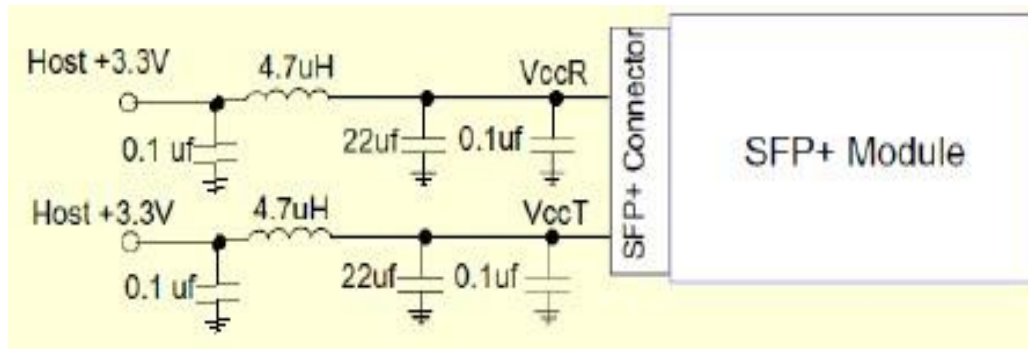

Recommended High-speed Interface Circuit

Mechanical Dimensions:

