

NE-GB-PxRx-x 1000BASE-T and 10/100/1000BASE-T Copper SFP Transceiver

Features

- Up to 1.25Gb/s bi-directional data links
- Hot-pluggable SFP footprint
- TX Disable and RX Los/without Los function
- Fully metallic enclosure for low EMI
- +3.3V single power supply
- Low power dissipation (1.05 W typical)
- Compact RJ-45 connector assembly
- Access to physical layer IC via 2-wire serial bus
- 1000 BASE-T operation in host systems with SERDES interface
- 10/100/1000Mbps compliant in host systems with SGMII interface



Applications

- 1.25 Gigabit Ethernet over Cat 5 cable

Description

NE-GB-PxRx-x Copper Small Form Pluggable (SFP) transceivers is high-performance, cost-effective module compliant with the Gigabit Ethernet and 1000BASE-T standards as specified in IEEE 802.3-2002 and IEEE 802.3ab, which supporting 1000Mbps data-rate up to 100 meters reach over unshielded twisted-pair category 5 cable. The module supports 1000 Mbps full duplex data-links with 5-level Pulse Amplitude Modulation (PAM) signals. The module provides standard serial ID information compliant with SFP MSA, which can be accessed with address of A0h via the 2-wire serial CMOS EEPROM protocol. The physical IC can also be accessed via 2-wire serial bus at address Ach.

Pin Definitions

Pin Diagram

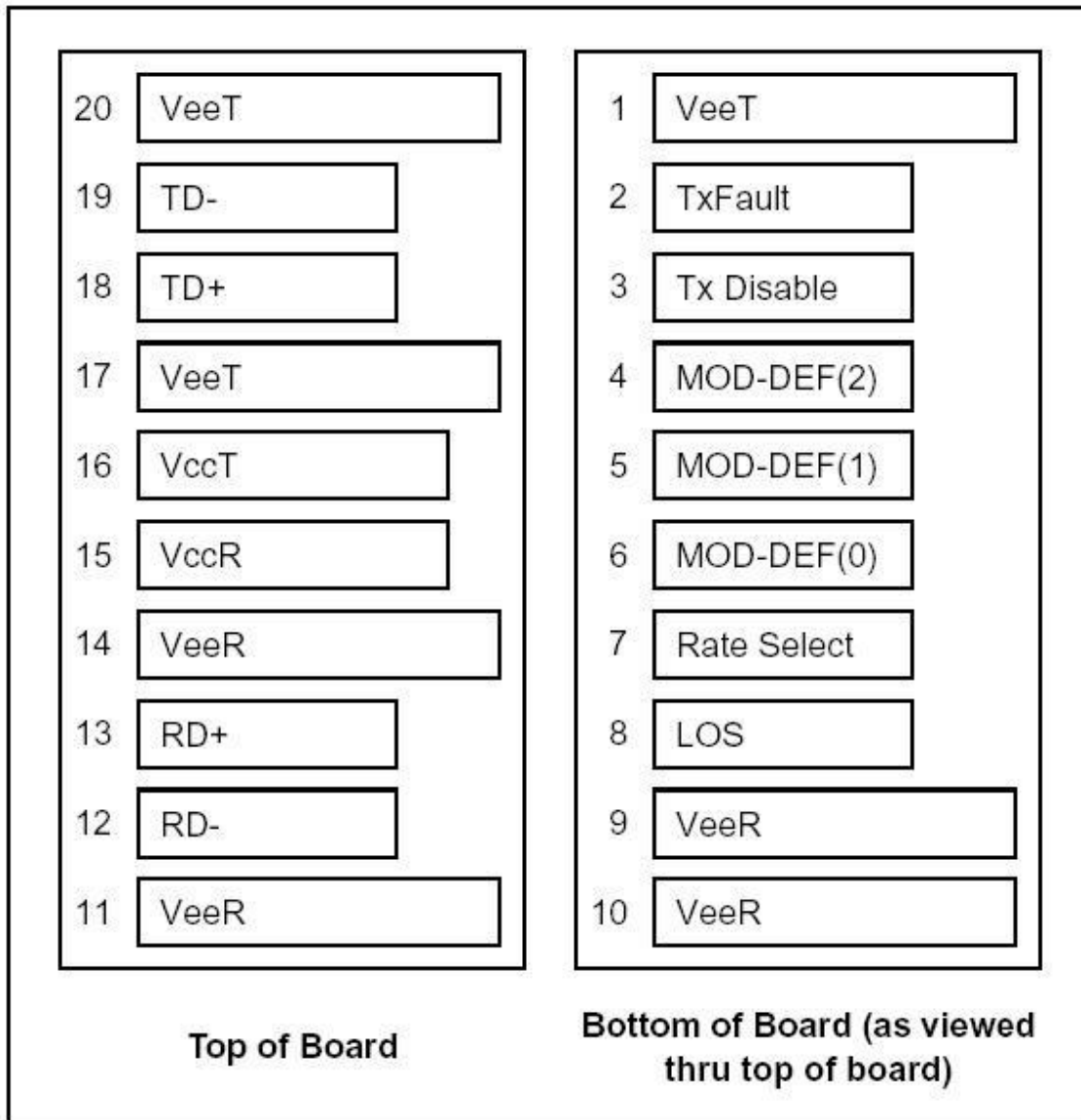

Figure 1. Pin Definitions

Pin Descriptions

Pin	Signal Name	Description	Plug Seq.	Notes
1	V _{EET}	Transmitter Ground	1	
2	TX FAULT	Transmitter Fault Indication	3	Note1
3	TX DISABLE	Transmitter Disable	3	Note2
4	MOD_DEF(2)	SDA Serial Data Signal	3	Note3
5	MOD_DEF(1)	SCL Serial Clock Signal	3	Note3
6	MOD_DEF(0)	TTL Low	3	Note3
7	Rate Select	Not Connected	3	
8	LOS	Loss of Signal	3	Note4
9	V _{EER}	Receiver ground	1	
10	V _{EER}	Receiver ground	1	
11	V _{EER}	Receiver ground	1	
12	RX-	Inv. Received Data Out	3	Note 5
13	RX+	Received Data Out	3	Note 5
14	V _{EER}	Receiver ground	1	
15	V _{CCR}	Receiver Power Supply	2	
16	V _{CCT}	Transmitter Power Supply	2	
17	V _{EET}	Transmitter Ground	1	
18	TX+	Transmit Data In	3	Note 6
19	TX-	Inv. Transmit Data In	3	Note 6
20	V _{EET}	Transmitter Ground	1	

Notes:

Plug Seq.: Pin engagement sequence during hot plugging.

- 1) TX Fault is not supported and is always connected to ground.
- 2) TX disable, an input used to reset the transceiver module, This pin is pulled up within the module with a 4.7 K Ω resistor.
 - Low (0 – 0.8 V): Transceiver on Between
 - (0.8 V and 2.0 V): Undefined
 - High (2.0 – 3.465 V): Transceiver in reset state
 - Open: Transceiver in reset state
- 3) Mod-Def 0,1,2. These are the module definition pins. They should be pulled up with a 4.7K~10K resistor on the host board. The pull-up voltage shall be V_{ccT} or V_{ccR}
 Mod-Def 0 is grounded by the module to indicate that the module is present Mod-Def 1 is the clock line of two wire serial interface for serial ID
 Mod-Def 2 is the data line of two wire serial interface for serial ID
- 4) RX_LOS (Loss of Signal): LVTTTL compatible with a maximum voltage of Host_V_{cc}. RX_LOS can enabled or disabled (Refer to Ordering information),RX_LOS is not used and is always tied to ground via 100-ohm resistor.
- 5) RD-/+ : These are the differential receiver outputs. They are AC coupled 100 differential lines which should be terminated with 100 (differential) at the user SERDES.
- 6) TD-/+ : These are the differential transmitter inputs. They are AC-coupled, differential lines with 100 differential termination inside the module.

+3.3V Volt Electrical Power Interface

+3.3V volt Electrical Power Interface						
Parameter	Symbol	Min	Typ	Max	Units	Notes/Conditions
Supply Current	Is		320	375	mA	1.2W max power over full range of voltage and temperature. See caution note below
Input Voltage	Vcc	3.13	3.3	3.47	V	Referenced to GND
Maximum Voltage	Vmax			3.6	V	

Low-speed signals, electronic characteristics

Low-Speed Signals, Electronic Characteristics						
Parameter	Symbol	Min	Max	Units	Notes/Conditions	
SFP Output LOW	VOL	0	0.5	V	4.7k to 10k pull-up to host_Vcc, measured at host side of connector	
SFP Output HIGH	VOH	host_Vcc - 0.5	host_Vcc + 0.3	V	4.7k to 10k pull-up to host_Vcc, measured at host side of connector	
SFP Input LOW	VIL	0	0.8	V	4.7k to 10k pull-up to Vcc, measured at SFP side of connector	
SFP Input HIGH	VIH	2	Vcc + 0.3	V	4.7k to 10k pull-up to Vcc, measured at SFP side of connector	

High-speed electrical interface, transmission line-SFP

High-Speed Electrical Interface Transmission Line-SFP						
Parameter	Symbol	Min	Typ	Max	Units	Notes/Conditions
Line Frequency	fL		125		MHz	5-level encoding, per IEEE 802.3
Tx Output Impedance	Zout,TX		100		Ohm	Differential, for all Frequencies between 1MHz and 125MHz
Rx Input Impedance	Zin,RX		100		Ohm	Differential, for all Frequencies between 1MHz and 125MHz

High-speed electrical interface, host-SFP

High-Speed Electrical Interface, Host-SFP						
Parameter	Symbol	Min	Typ	Max	Units	Notes/Conditions
Single ended data input swing	Vinsing	250		1200	mV	Single ended
Single ended data output swing	Voutsing	350		800	mV	Single ended
Rise/Fall Time	Tr,Tf		175		psec	20%-80%
Tx Input Impedance	Zin		50		Ohm	Single ended
Rx Output Impedance	Zout		50		Ohm	Single ended

General specifications

General						
Parameter	Symbol	Min	Typ	Max	Units	Notes/Conditions
Data Rate	BR	10		1000	Mb/sec	IEEE 802.3 compatible. See Notes 2 through 4 below
Cable Length	L			100	m	Category 5 UTP. BER <10 ⁻¹²

Notes:

1. Clock tolerance is +/- 50 ppm
2. By default, the GE-GB-PxRC-x is a full duplex device in preferred master mode
3. Automatic crossover detection is enabled. External crossover cable is not required

Environmental specifications

Parameter	Symbol	Min	Typical	Max	Unit
Operating Case Temperature	Tc	0		+70	°C
Storage Temperature		-40		+85	°C

Recommended Host Board Power Supply Circuit

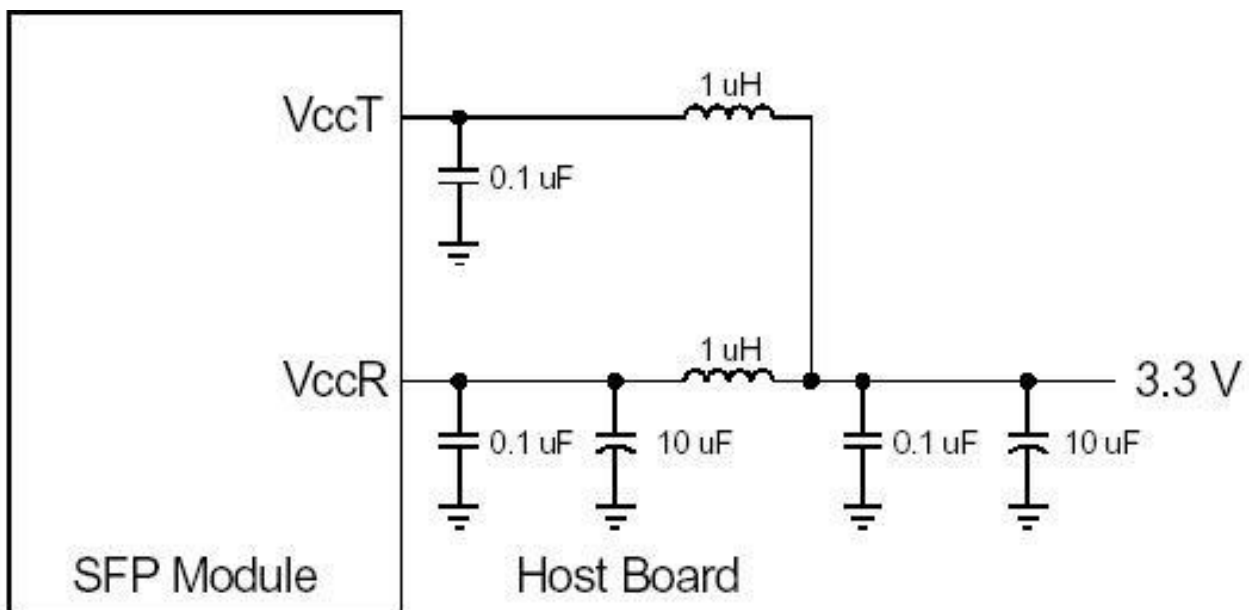
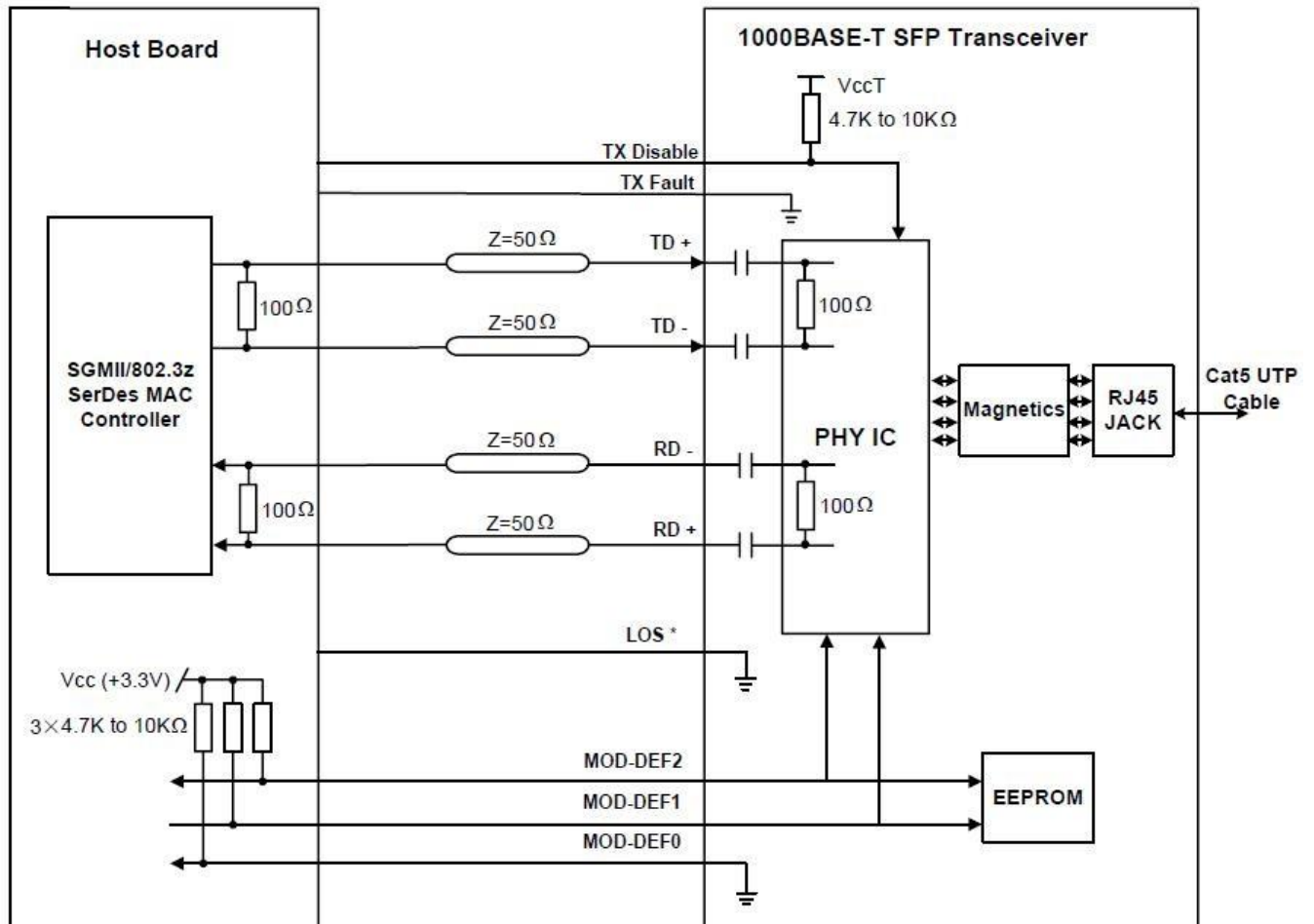

Figure 2. Recommended Host Board Power Supply Circuit

Recommended Interface Circuit



***NOTE:** The consumer can choose whether the module has los signal or not, please refer to the Pin Descriptions (page2-page3) and the Ordering Information (page11).

Figure 3. Recommended Host Board Power Supply Circuit

EEPROM Information

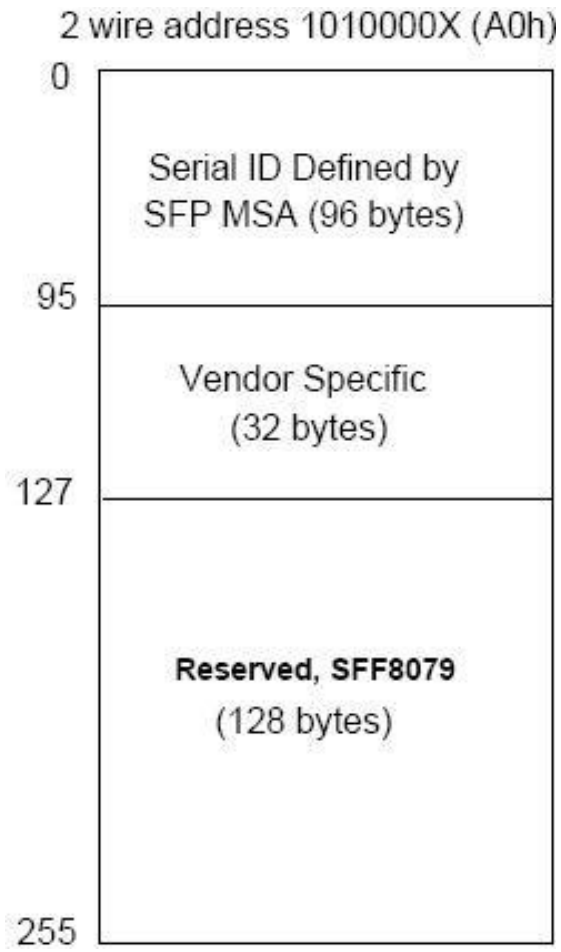

Figure 4. 2-wire Serial Memory Map

Physical Layer IC Register

		Page Address	
		Page 0 (Copper)	Page 1 (Fiber)
Register Address	0	Control Register	Control Register
	1	Status Register	Status Register
	2	PHY Identifier	
	3	PHY Identifier	
	4	Auto-Neg Advertisement Register	Auto-Neg Advertisement Register
	5	Link Partner Ability Register	Link Partner Ability Register
	6	Auto-Neg Expansion Register	Auto-Neg Expansion Register
	7	Next Page Transmit Register	Next Page Transmit Register
	8	Link Partner Next Page Register	Link Partner Next Page Register
	9	1000BASE-T Control Register	
	10	1000BASE-T Status Register	
	15	Extended Status Register	
	16	PHY Specific Control Register	
	17	PHY Specific Status Register	PHY Specific Status Register
	18	Interrupt Enable Register	Interrupt Enable Register
	19	Interrupt Status Register	Interrupt Status Register
	20	Extended PHY Specific Control Register	
	21	Receive Error Counter Register	
	22	Extended Address Register	
	23	Global Status Register	
	24	LED Control Register	
	25	Manual LED Override Register	
	26	Extended PHY Specific Control 2 Register	
	27	Extended PHY Specific Status Register	
	28	MDI[0:3] Virtual Cable Tester™ Status (Pages 0-3); 1000BASE-T Pair Skew (Page 4); 100BASE-T Pair, 1000BASE-T Pair Swap and Polarity (Page 5)	
	29	Extended Address	
	30	Calibration Override (Page 3); Force Gigabit (Page 7); Class A (Page 11); CRC Checker result (Page 12); Test Enable Control (Page 16); Miscellaneous Control (Page 18)	

Figure 5. Phy IC Register List

How to enable NE-GB-PxRx-x work at 10/100/1000BASE-T

The physical IC can also be accessed via 2wire serial bus at address Ach. NE-GB-PxRx-x supports 1000Mbps full duplex SerDes interface default. But it also can operate with SGMII (without clocks) interface by software configuration when HOST is SGMII interface.

Please refer the following steps to configure:

Step 1: Access the PHY at 0xAC via two-wire serial interface. Step 2:
Configure 0xAC as below table

PHY Address: 0xAC		
Register Address	Write data	Description
0x1Bh	0x9084h	Enable SGMII mode
0x00h	0x9140h	Software reset to allow changes to take effect
0x16h	0x0000h	Select page 0
0x09h	0x0F00h	Advertise 1000BASE-T *FD/HD
0x04h	0x0DE1h	Advertise 100/10BASE-T *FD/HD
0x00h	0x9140h	Software reset to allow changes to take effect

Notes:

FD: Full Duplex

HD: Half Duplex

How to disable Auto-negotiation on GE-GB-PxRx-x

NE-GB-PxRx-x works at mode of “Auto-negotiation enable” default. But it also can operate with “Auto-negotiation disable”. Please refer the following steps to configure:

Step 1: Access the PHY at 0xAC via two-wire serial interface. Step 2:
Configure 0xAC as below table

PHY Address: 0xAC		
Register Address	Write data	Description
0x16h	0x0001h	Select page 1
0x00h	0x8140h	Disable Auto-negotiation
0x16h	0x0000h	Select page 0

Mechanical Specifications

The host-side of the NE-GB-PxRC-x conforms to the mechanical specifications outlined in the SFP MSA1. The front portion of the SFP (part extending beyond the face plate of the host) is larger to accommodate the RJ-45 connector

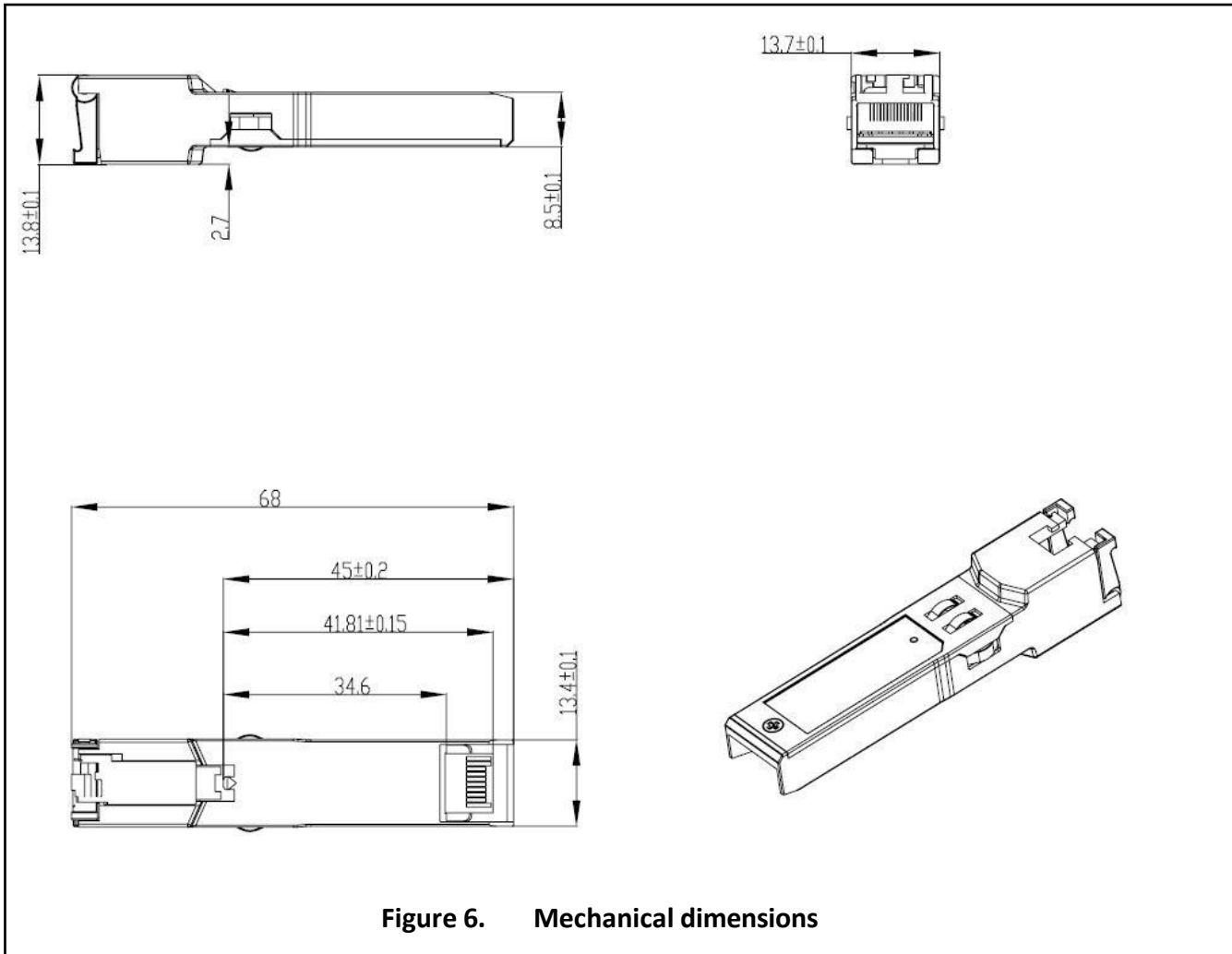

Regulatory Compliance

SFP-Coper transceiver is designed to be Class I Laser safety compliant and is certified per the following standards:

Feature	Agency	Standard	Certificate / Comments
Environmental protection	SGS	RoHS Directive 2011/65/EU	GZ090319751A/CHEM

Ordering Information

Part number	Speed mode	MAC interface	TX Disable function	Link Indicator on RX_LOS Pin	Temp
NE-GB-P1RCD	10/100/1000Mbps	SGMII	Yes	Yes	0~70°C
NE-GB-P1RCT	10/100/1000Mbps	SGMII	Yes	Yes	-40~85°C