

**NPB-5448-L4C(D)**  
**2.488Gbps SFP Bi-Directional Transceiver, 40km Reach**  
**1550nm TX / 1490 nm RX**

**Features**

Dual data-rate of 2.488Gbps/2.125Gbps operation

1550nm DFB laser and PIN photo detector for 40km transmission

Compliant with SFP MSA and SFF-8472 with duplex LC receptacle

Digital Diagnostic Monitoring:

Internal Calibration or External Calibration

Compatible with RoHS

+3.3V single power supply

Operating case temperature: Standard: 0 to +70°C Industrial: -40 to +85°C



**Applications**

SDH STM-16 and SONET OC-48 system

2X Fiber Channel

Switch to Switch interface

Switched backplane applications

Router/Server interface

Other optical transmission systems

**Description**

The SFP transceivers are high-performance, cost-effective modules supporting dual data-rate of 2.488Gbps/2.125Gbps and 40km transmission distance with SMF. The transceiver consists of three sections: a DFB laser transmitter, a PIN photodiode integrated with a trans-impedance preamplifier (TIA) and MCU control unit. All modules satisfy class I laser safety requirements. The transceivers are compatible with SFP Multi-Source Agreement (MSA) and SFF-8472. For further information, please refer to SFP MSA.

## Module Block Diagram

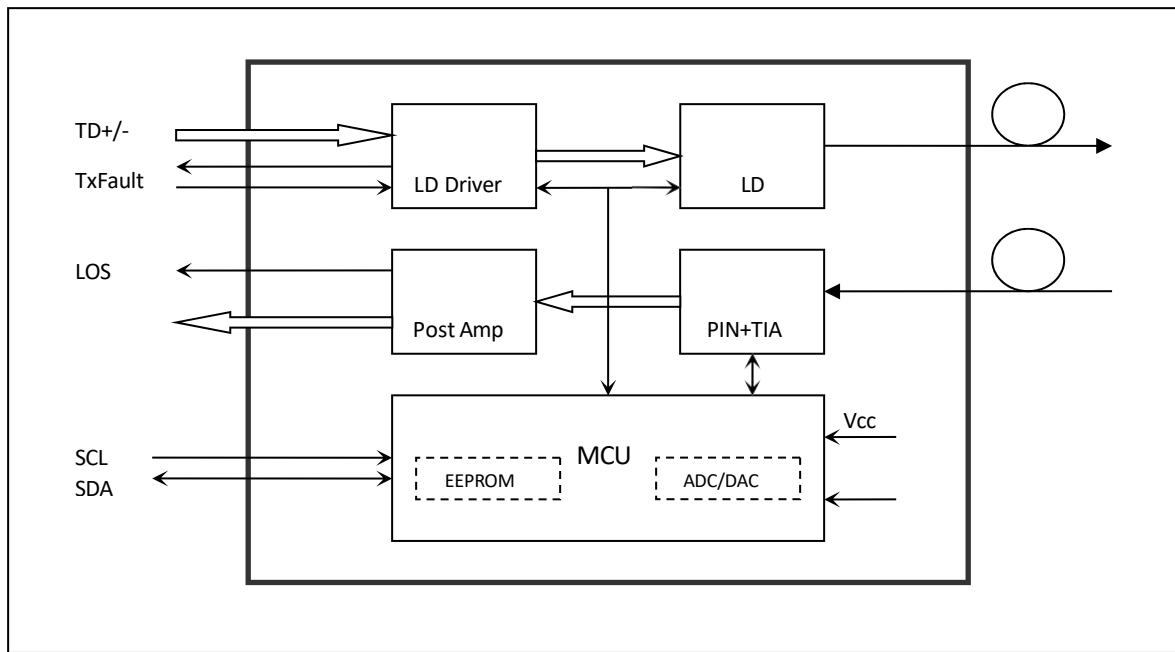

## Absolute Maximum Ratings

**Table 1 - Absolute Maximum Ratings**

| Parameter           | Symbol | Min  | Max | Unit |
|---------------------|--------|------|-----|------|
| Supply Voltage      | Vcc    | -0.5 | 4.5 | V    |
| Storage Temperature | Ts     | -40  | +85 | °C   |
| Operating Humidity  | -      | 5    | 85  | %    |

## Recommended Operating Conditions

**Table 2 - Recommended Operating Conditions**

| Parameter                  | Symbol | Min  | Typical | Max  | Unit |
|----------------------------|--------|------|---------|------|------|
| Operating Case Temperature | Tc     | 0    |         | +70  | °C   |
| Power Supply Voltage       | Vcc    | 3.13 | 3.3     | 3.47 | V    |
| Power Supply Current       | Icc    |      |         | 300  | mA   |
| Data Rate                  |        |      | 2.67    |      | Mbps |

## Optical and Electrical Characteristics

**Table 3 - Optical and Electrical Characteristics**

| Parameter                        | Symbol                         | Min  | Typical | Max             | Unit     | Notes |
|----------------------------------|--------------------------------|------|---------|-----------------|----------|-------|
| <b>Transmitter</b>               |                                |      |         |                 |          |       |
| Centre Wavelength                | $\lambda_c$                    | 1530 | 1550    | 1570            | nm       |       |
| Spectral Width (-20dB)           | $\Delta\lambda$                |      |         | 1               | nm       |       |
| Average Output Power             | P <sub>out</sub>               | -2   |         | +3              | dBm      | 1     |
| Extinction Ratio                 | ER                             | 9    |         |                 | dB       |       |
| Optical Rise/Fall Time (20%~80%) | t <sub>r</sub> /t <sub>f</sub> |      |         | 0.16            | ns       |       |
| Data Input Swing Differential    | V <sub>IN</sub>                | 400  |         | 1800            | mV       | 2     |
| Input Differential Impedance     | Z <sub>IN</sub>                | 90   | 100     | 110             | $\Omega$ |       |
| TX Disable                       | Disable                        | 2.0  |         | V <sub>cc</sub> | V        |       |
|                                  | Enable                         | 0    |         | 0.8             | V        |       |
| TX Fault                         | Fault                          | 2.0  |         | V <sub>cc</sub> | V        |       |
|                                  | Normal                         | 0    |         | 0.8             | V        |       |
| <b>Receiver</b>                  |                                |      |         |                 |          |       |
| Centre Wavelength                | $\lambda_c$                    | 1470 |         | 1510            | nm       |       |
| Receiver Sensitivity             |                                |      |         | -18             | dBm      | 3     |
| Receiver Overload                |                                | 0    |         |                 | dBm      | 3     |
| LOS De-Assert                    | LOS <sub>D</sub>               |      |         | -23             | dBm      |       |
| LOS Assert                       | LOS <sub>A</sub>               | -30  |         |                 | dBm      |       |
| LOS Hysteresis                   |                                | 1    |         | 4               | dB       |       |
| Data Output Swing Differential   | V <sub>out</sub>               | 400  |         | 1800            | mV       | 4     |
| LOS                              | High                           | 2.0  |         | V <sub>cc</sub> | V        |       |
|                                  | Low                            |      |         | 0.8             | V        |       |

**Notes:**

1. The optical power is launched into SMF.
2. PECL input, internally AC-coupled and terminated.
3. Measured with a PRBS 2<sup>23</sup>-1 test pattern @2488Mbps, BER ≤1×10<sup>-12</sup>.
4. Internally AC-coupled.

## Timing and Electrical

**Table 4 - Timing and Electrical**

| Parameter                                       | Symbol         | Min | Typical | Max | Unit |
|---|----------------|-----|---------|-----|------|
| Tx Disable Negate Time                          | t_on           |     |         | 1   | ms   |
| Tx Disable Assert Time                          | t_off          |     |         | 10  | μs   |
| Time To Initialize, including Reset of Tx Fault | t_init         |     |         | 300 | ms   |
| Tx Fault Assert Time                            | t_fault        |     |         | 100 | μs   |
| Tx Disable To Reset                             | t_reset        | 10  |         |     | μs   |
| LOS Assert Time                                 | t_loss_on      |     |         | 100 | μs   |
| LOS De-assert Time                              | t_loss_off     |     |         | 100 | μs   |
| Serial ID Clock Rate                            | f_serial_clock |     |         | 400 | KHz  |
| MOD_DEF (0:2)-High                              | VH             | 2   |         | Vcc | V    |
| MOD_DEF (0:2)-Low                               | VL             |     |         | 0.8 | V    |

## Diagnostics

**Table 5 – Diagnostics Specification**

| Parameter    | Range      | Unit | Accuracy | Calibration         |
|--------------|------------|------|----------|---------------------|
| Temperature  | 0 to +70   | °C   | ±3°C     | Internal / External |
| Voltage      | 3.0 to 3.6 | V    | ±3%      | Internal / External |
| Bias Current | 0 to 100   | mA   | ±10%     | Internal / External |
| TX Power     | -2 to 3    | dBm  | ±3dB     | Internal / External |
| RX Power     | -18 to 0   | dBm  | ±3dB     | Internal / External |

## Digital Diagnostic Memory Map

The transceivers provide serial ID memory contents and diagnostic information about the present operating conditions by the 2-wire serial interface (SCL, SDA).

The diagnostic information with internal calibration or external calibration all are implemented, including received power monitoring, transmitted power monitoring, bias current monitoring, supply voltage monitoring and temperature monitoring.

The digital diagnostic memory map specific data field defines as following.

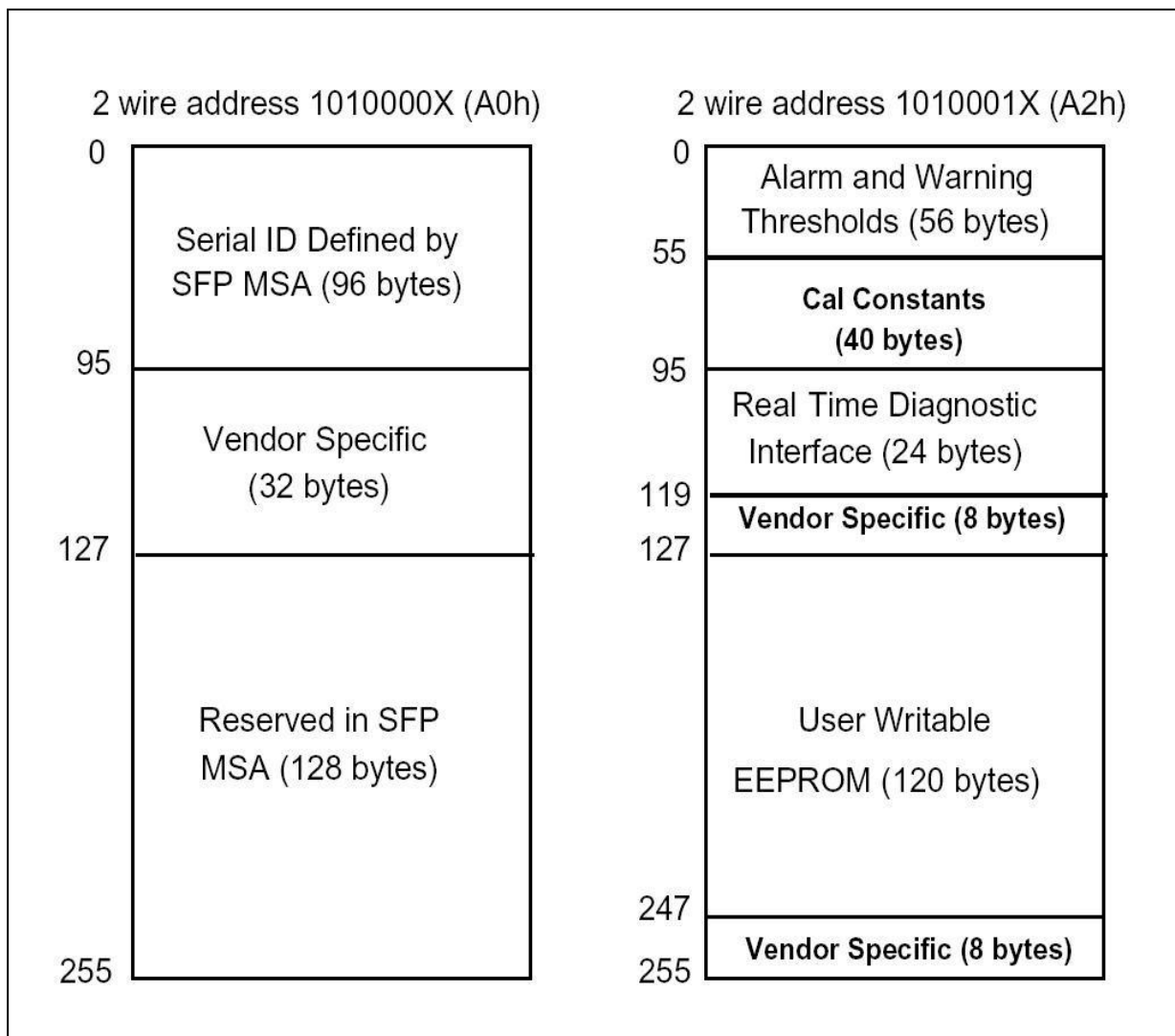

## Pin Definitions

Pin Diagram

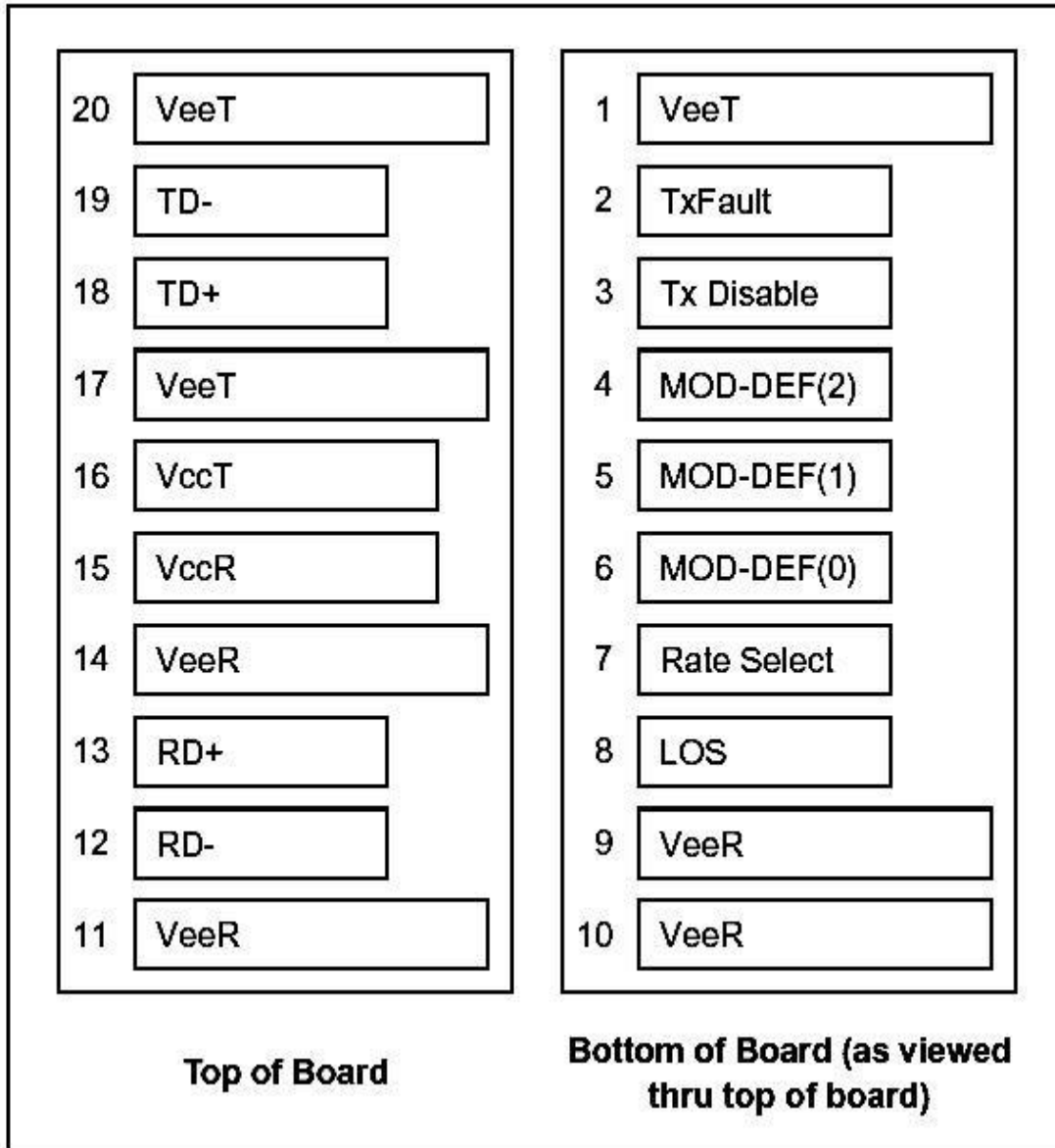

## Pin Descriptions

| Pin | Signal Name      | Description                  | Plug Seq. | Notes  |
|-----|------------------|------------------------------|-----------|--------|
| 1   | V <sub>EET</sub> | Transmitter Ground           | 1         |        |
| 2   | TX FAULT         | Transmitter Fault Indication | 3         | Note 1 |
| 3   | TX DISABLE       | Transmitter Disable          | 3         | Note 2 |
| 4   | MOD_DEF(2)       | SDA Serial Data Signal       | 3         | Note 3 |
| 5   | MOD_DEF(1)       | SCL Serial Clock Signal      | 3         | Note 3 |
| 6   | MOD_DEF(0)       | TTL Low                      | 3         | Note 3 |
| 7   | Rate Select      | Not Connected                | 3         |        |
| 8   | LOS              | Loss of Signal               | 3         | Note 4 |
| 9   | V <sub>EER</sub> | Receiver ground              | 1         |        |
| 10  | V <sub>EER</sub> | Receiver ground              | 1         |        |
| 11  | V <sub>EER</sub> | Receiver ground              | 1         |        |
| 12  | RD-              | Inv. Received Data Out       | 3         | Note 5 |
| 13  | RD+              | Received Data Out            | 3         | Note 5 |
| 14  | V <sub>EER</sub> | Receiver ground              | 1         |        |
| 15  | V <sub>CCR</sub> | Receiver Power Supply        | 2         |        |
| 16  | V <sub>CCT</sub> | Transmitter Power Supply     | 2         |        |
| 17  | V <sub>EET</sub> | Transmitter Ground           | 1         |        |
| 18  | TD+              | Transmit Data In             | 3         | Note 6 |
| 19  | TD-              | Inv. Transmit Data In        | 3         | Note 6 |
| 20  | V <sub>EET</sub> | Transmitter Ground           | 1         |        |

### Notes:

Plug Seq.: Pin engagement sequence during hot plugging.

- TX Fault is an open collector output, which should be pulled up with a 4.7k~10kΩ resistor on the host board to a voltage between 2.0V and V<sub>cc</sub>+0.3V. Logic 0 indicates normal operation; Logic 1 indicates a laser fault of some kind. In the low state, the output will be pulled to less than 0.8V.
- TX Disable is an input that is used to shut down the transmitter optical output. It is pulled up within the module with a 4.7k~10kΩ resistor. Its states are:
 

|                       |                      |
|-----------------------|----------------------|
| Low (0 to 0.8V):      | Transmitter on       |
| (>0.8V, < 2.0V):      | Undefined            |
| High (2.0 to 3.465V): | Transmitter Disabled |
| Open:                 | Transmitter Disabled |
- Mod-Def 0,1,2. These are the module definition pins. They should be pulled up with a 4.7k~10kΩ resistor on the host board. The pull-up voltage shall be V<sub>ccT</sub> or V<sub>ccR</sub>.  
 Mod-Def 0 is grounded by the module to indicate that the module is present  
 Mod-Def 1 is the clock line of two wire serial interface for serial ID  
 Mod-Def 2 is the data line of two wire serial interface for serial ID
- LOS is an open collector output, which should be pulled up with a 4.7k~10kΩ resistor. Pull up voltage between 2.0V and V<sub>cc</sub>+0.3V. Logic 1 indicates loss of signal; Logic 0 indicates normal operation. In the low state, the output will be pulled to less than 0.8V.
- RD-/+ : These are the differential receiver outputs. They are internally AC-coupled 100 differential lines which should be terminated with 100Ω (differential) at the user SERDES.
- TD-/+ : These are the differential transmitter inputs. They are internally AC-coupled, differential lines with 100Ω differential termination inside the module.

Recommended Interface Circuit

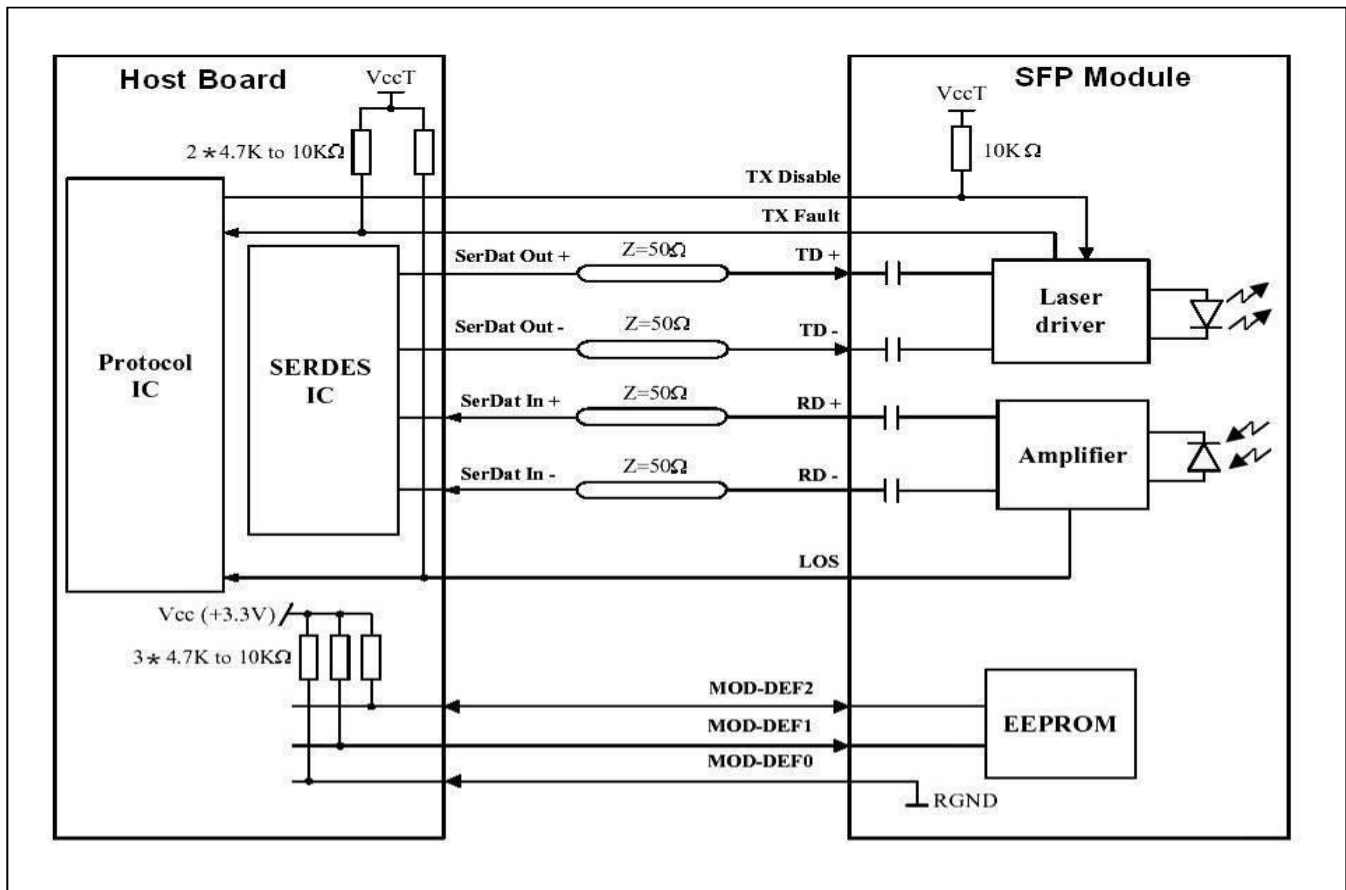

Mechanical Dimensions

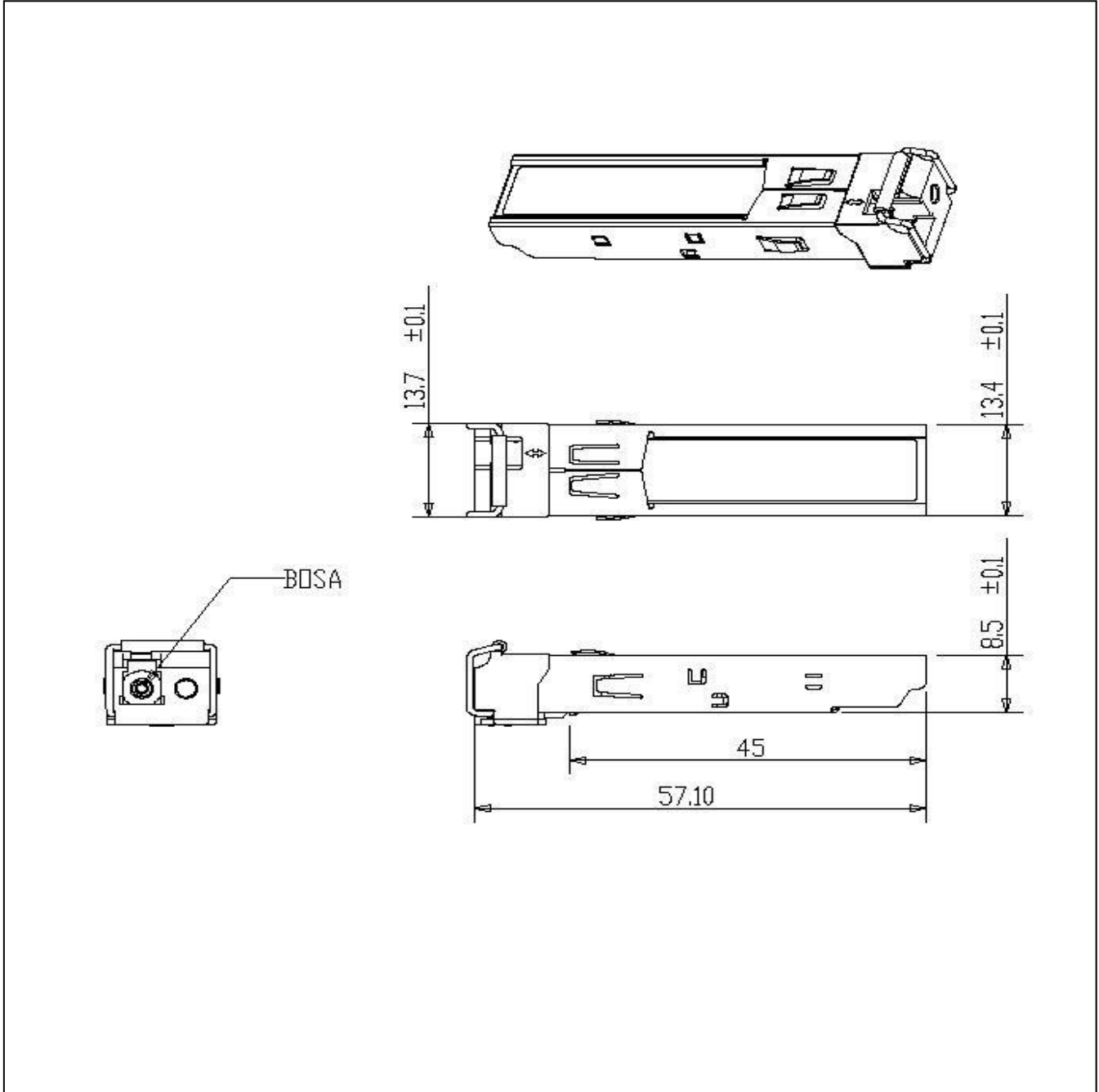

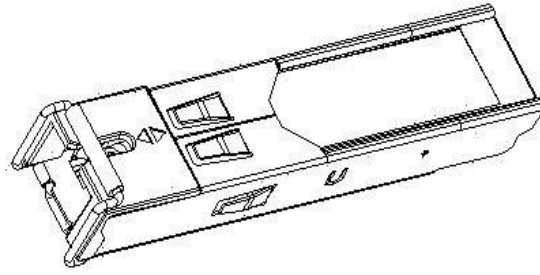
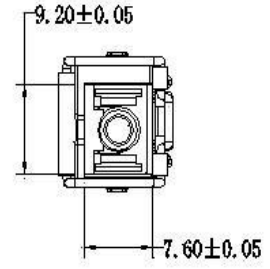
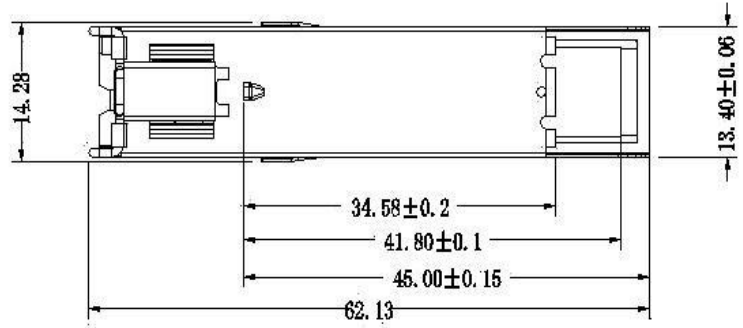
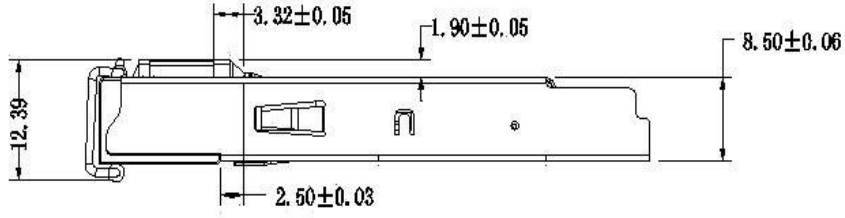

## Regulatory Compliance

SFP transceiver is designed to be Class I Laser safety compliant and is certified per the following standards

| Feature                  | Agency | Standard  | Certificate / Comments |
|--------------------------|--------|---|------------------------|
| Laser Safety             | FDA    | CDRH 21 CFR 1040 and Laser Notice No. 50                    | 1120295-000            |
| Product Safety           | BST    | EN 60825-1: 2007<br>EN 60825-2: 2004<br>EN 60950-1: 2006    | BT0905142001           |
| Environmental protection | SGS    | RoHS Directive 2002/95/EC                                   | GZ0902007478/CHEM      |
| EMC                      | CCIC   | EN 55022: 2006+A1: 2007<br>EN 55024: 1998+A1: 2001+A2: 2003 | CTE09020023            |

## Ordering information

| Part Number    | Product Description  |
|----------------|--|
| NPB-5448S-L4C  | TX1550nm/RX1490nm, 2.488Gbps, SC,40km, 0°C~+70°C                                     |
| NPB-5448S-L4CD | TX1550nm/RX1490nm, 2.488Gbps, SC,40km, 0°C~+70°C, With Digital Diagnostic Monitoring |
| NPB-5448L-L4C  | TX1550nm/RX1490nm, 2.488Gbps, LC,40km, 0°C~+70°C                                     |
| NPB-5448L-L4CD | TX1550nm/RX1490nm, 2.488Gbps, LC,40km, 0°C~+70°C, With Digital Diagnostic Monitoring |