

## 10G SFP+ ER 1550nm 40km Optical Transceiver NPP-55192-04CD

### Features

Compliant with SFF-8431, SFF-8432 and IEE802.3ae

Cooled EML transmitter and PIN receiver

link length up to 40km

Low Power Dissipation 1.5W Maximum

-5°C to 70°C Operating Case Temperature

Single 3.3V power supply

Diagnostic Performance Monitoring of module temperature, supply Voltages, laser bias current, transmit optical power, receive optical power

RoHS6 compliant and lead free 



### Applications

10GBASE-ER (with/without FEC)

10G Fiber Channel (with/without FEC)

### Description

SFP+ER 1550nm Transceiver is a "Limiting module", designed for 10GBASE-ER, and 2G/4G/ 8G/10G Fiber-Channel applications.

The transceiver consists of two sections: The transmitter section incorporates a cooled EML laser. And the receiver section consists of a PIN photodiode integrated with a TIA. All modules satisfy class I laser safety requirements. Digital diagnostics functions are available via a 2-wire serial interface, as specified in SFF-8472, which allows real-time access to device operating parameters such as transceiver temperature, laser bias current, transmitted optical power, received optical power and transceiver supply voltage.

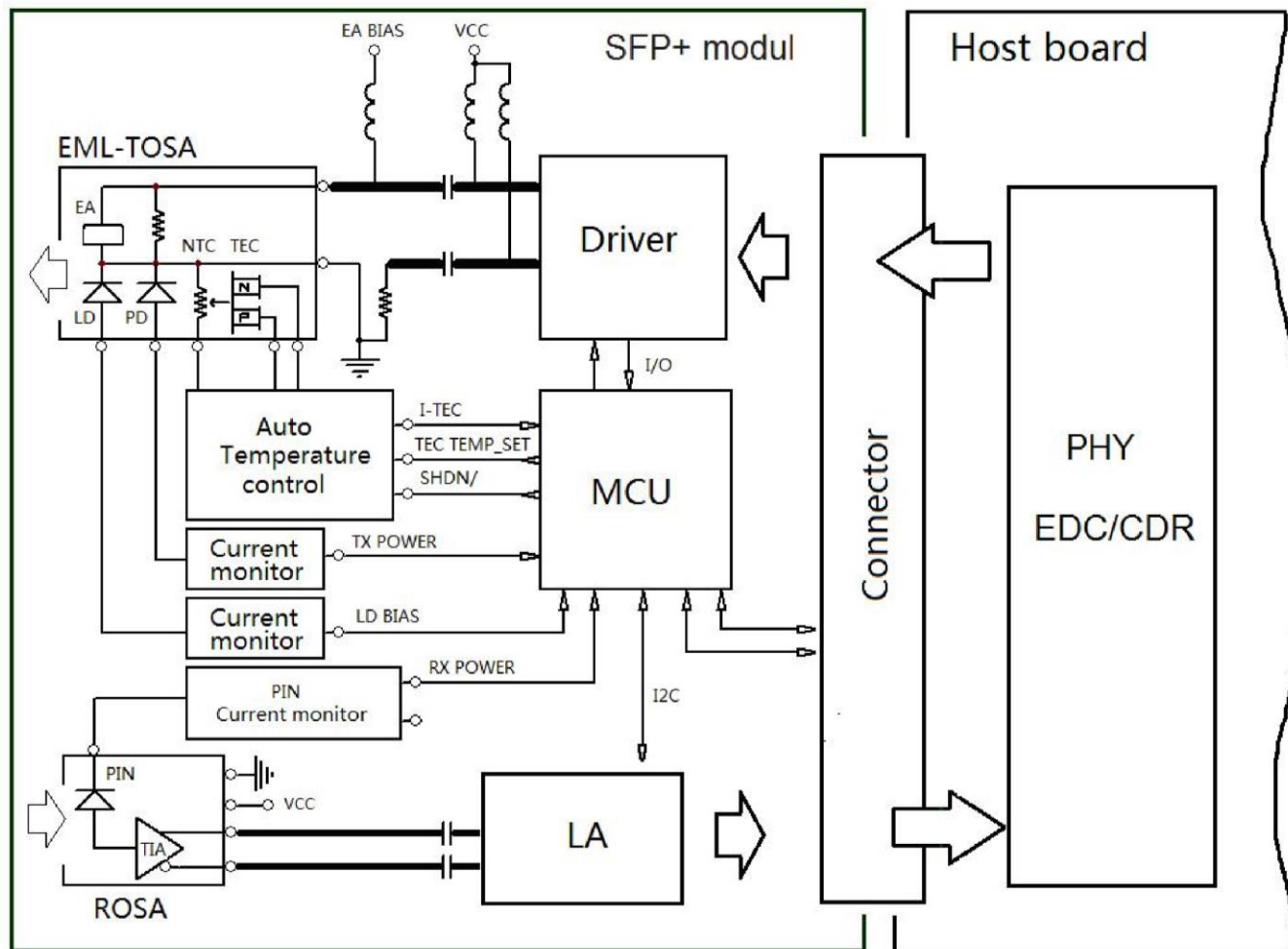

Figure1. Module Block Diagram

### Absolute Maximum Ratings

| Parameter           | Symbol | Min  | Max | Unit |
|---------------------|--------|------|-----|------|
| Supply Voltage      | Vcc    | -0.5 | 3.8 | V    |
| Storage Temperature | Tst    | -40  | 85  | °C   |
| Relative Humidity   | Rh     | 0    | 85  | %    |

### Operating Conditions

| Parameter                  | Symbol | Min  | Typical | Max  | Unit |
|----------------------------|--------|------|---------|------|------|
| Supply Voltage             | Vcc    | 3.13 | 3.3     | 3.46 | V    |
| Supply current             | Icc    | -    | 360     | 450  | mA   |
| Operating Case temperature | Tca    | -5   | -       | 70   | °C   |
| Module Power Dissipation   | Pm     | -    | 1.2     | 1.5  | W    |

## Transmitter Specifications – Optical

| Parameter                         | Symbol                | Min  | Typical | Max  | Unit  |
|-----------------------------------|-----------------------|------|---------|------|-------|
| Center Wavelength                 | $\lambda_c$           | 1530 |         | 1565 | nm    |
| Spectral Width (-20dB)            | $\Delta \lambda_{20}$ | -    | -       | 0.3  | nm    |
| Average Optical Power             | Po                    | -1   | -       | +3   | dBm   |
| Optical Power in OMA              | OMA                   | -2.1 |         |      | dBm   |
| Side Mode Suppression Ratio       | SMSR                  | 30   | -       | -    | dB    |
| Optical Transmit Power (disabled) | PTX_DISABLE           | -    | -       | -30  | dBm   |
| Extinction Ratio                  | ER                    | 8.2  | -       | -    | dB    |
| Relative Intensity Noise          | RIN                   | -    | -       | -128 | dB/Hz |
| Optical Return Loss Tolerance     | Orl                   | -    | -       | 21   | dB    |

## Receiver Specifications – Optical

| Parameter                                      | Symbol    | Min   | Typical | Max   | Unit |
|--|-----------|-------|---------|-------|------|
| Input Operating Wavelength                     | $\lambda$ | 1260  | -       | 1600  | nm   |
| Average receive power                          | Pavg      | -17.8 | -       | -1.0  | dBm  |
| Receiver sensitivity in 10.3Gbps(OMA)          | Rsen1     | -     | -       | -16   | dBm  |
| Stressed receiver sensitivity in 10.3Gbps(OMA) | Rsen2     | -     | -       | -16.3 | dBm  |
| Reflectance                                    | Rrx       | -     | -       | -26   | dB   |
| LOS Asserted                                   | Lsa       | -28   | -       | -     | dBm  |
| LOS De-Asserted                                | Lda       | -     | -       | -19   | dBm  |
| LOS Hysteresis                                 | Lh        | 0.5   | -       | -     | dB   |

### Notes:

[1] Measured with conformance test signal for BER =  $10^{-12}$ . The stressed sensitivity values in the table are for system level BER measurements which include the effects of CDR circuits. It is recommended that at least 0.4 dB additional margin be allocated if component level measurements are made without the effects of CDR circuits.

## Transmitter Specifications – Electrical

| Parameter                    | Symbol  | Min | Typical | Max      | Unit     |
|------------------------------|---------|-----|---------|----------|----------|
| Data Rate                    | Mra     | 0.6 | 10.3    | 11.3     | Gbps     |
| Input differential impedance | Rim     | -   | 100     | -        | $\Omega$ |
| Differential data Input      | VtxDIFF | 120 | -       | 850      | mV       |
| Transmit Disable Voltage     | VD      | 2.0 | -       | Vcc3+0.3 | V        |
| Transmit Enable Voltage      | Ven     | 0   | -       | +0.8     | V        |
| Transmit Disable Assert Time | Vn      | -   | -       | 100      | us       |

## Receiver Specifications – Electrical

| Parameter                 | Symbol   | Min | Typical | Max       | Unit |
|---------------------------|----------|-----|---------|-----------|------|
| Data Rate                 | Mra      | 0.6 | 10.3    | 11.3      | Gbps |
| Differential Output Swing | Vout P-P | 350 | -       | 850       | mV   |
| Rise/Fall Time            | Tr / Tf  | 24  | -       | -         | ps   |
| Loss of Signal –Asserted  | VOH      | 2   | -       | Vcc3+0.3- | V    |
| Loss of Signal –Negated   | VOL      | 0   | -       | +0.4      | V    |

## Digital Diagnostic Functions

| Parameter                     | Symbol    | Min.  | Max   | Unit | Notes                 |
|-------------------------------|-----------|-------|-------|------|-----------------------|
| <b>Accuracy</b>               |           |       |       |      |                       |
| Transceiver Temperature       | DMI_Temp  | -3    | +3    | degC | Over operating temp   |
| TX Output optical power       | DMI_TX    | -3    | +3    | dB   |                       |
| RX Input optical power        | DMI_RX    | -3    | +3    | dB   | -3dBm to -12dBm range |
| Transceiver Supply voltage    | DMI_VCC   | -0.08 | +0.08 | V    | Full operating range  |
| Bias current monitor          | DMI_Ibias | -10%  | 10%   | mA   |                       |
| <b>Dynamic Range Accuracy</b> |           |       |       |      |                       |
| Transceiver Temperature       | DMI_Temp  | -5    | 70    | degC |                       |
| TX Output optical power       | DMI_TX    | -1    | +2    | dBm  |                       |
| RX Input optical power        | DMI_RX    | -18   | 0     | dBm  |                       |
| Transceiver Supply voltage    | DMI_VCC   | 3.0   | 3.6   | V    |                       |
| Bias current monitor          | DMI_Ibias | 0     | 100   | mA   |                       |

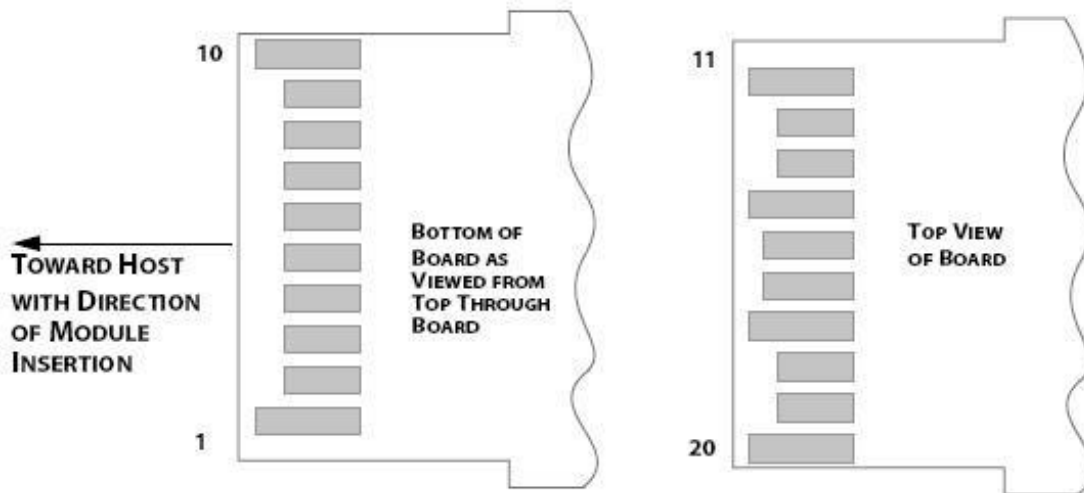
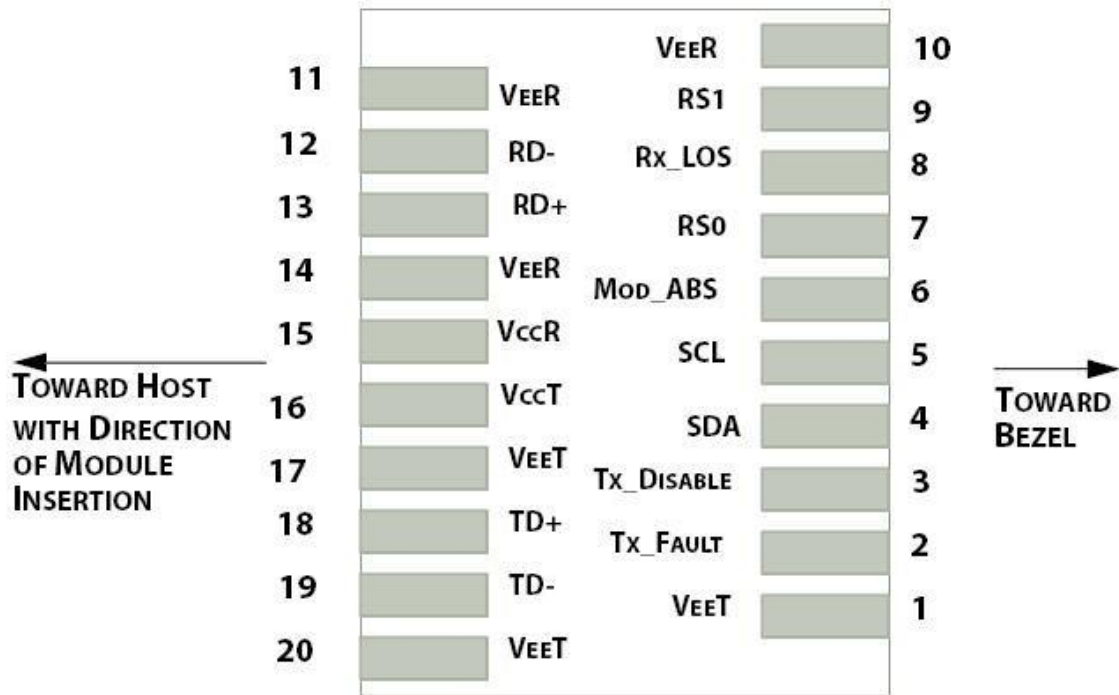

Figure2.Electrical Pin-out Details

## Pin Descriptions

| Pin | Symbol       | Name/Description  |
|-----|--------------|---|
| 1   | VEET [1]     | Transmitter Ground  |
| 2   | Tx_FAULT [2] | Transmitter Fault   |
| 3   | Tx_DIS [3]   | Transmitter Disable. Laser output disabled on high or open    |
| 4   | SDA [2]      | 2-wire Serial Interface Data Line                             |
| 5   | SCL [2]      | 2-wire Serial Interface Clock Line                            |
| 6   | MOD_ABS [4]  | Module Absent. Grounded within the module                     |
| 7   | RS0 [5]      | Rate Select 0   |
| 8   | RX_LOS [2]   | Loss of Signal indication. Logic 0 indicates normal operation |
| 9   | RS1 [5]      | Rate Select 1   |
| 10  | VEER [1]     | Receiver Ground   |
| 11  | VEER [1]     | Receiver Ground   |
| 12  | RD-          | Receiver Inverted DATA out. AC Coupled                        |
| 13  | RD+          | Receiver DATA out. AC Coupled                                 |
| 14  | VEER [1]     | Receiver Ground   |
| 15  | VCCR         | Receiver Power Supply   |
| 16  | VCCT         | Transmitter Power Supply                                      |
| 17  | VEET [1]     | Transmitter Ground  |
| 18  | TD+          | Transmitter DATA in. AC Coupled                               |
| 19  | TD-          | Transmitter Inverted DATA in. AC Coupled                      |
| 20  | VEET [1]     | Transmitter Ground  |

### Notes:

[1] Module circuit ground is isolated from module chassis ground within the module.

[2].should be pulled up with 4.7k – 10k ohms on host board to a voltage between 3.15V and 3.6V.

[3]Tx\_Disable is an input contact with a 4.7 kΩ to 10 kΩ pullup to VccT inside the module.

[4]Mod\_ABS is connected to VeeT or VeeR in the SFP+ module. The host may pull this contact up to Vcc\_Host with a resistor in the range 4.7 kΩ to 10 kΩ. Mod\_ABS is asserted “High” when the SFP+ module is physically absent from a host slot.

[5]RS0 and RS1 are module inputs and are pulled low to VeeT with > 30 kΩ resistors in the module.

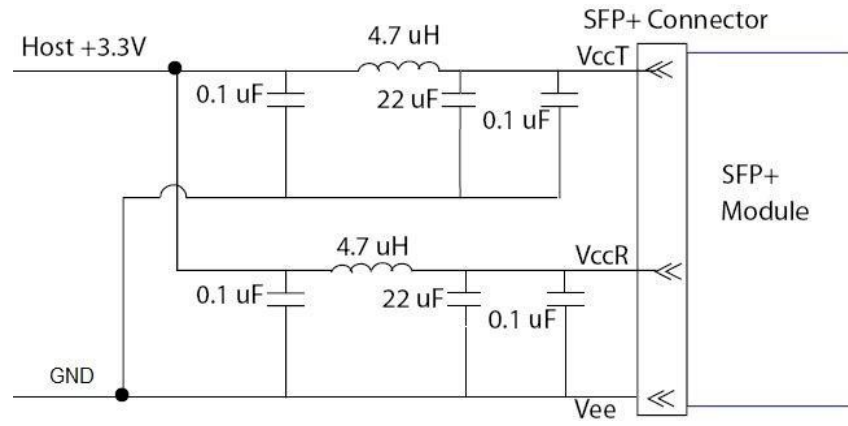

**Figure3. Host Board Power Supply Filters Circuit**

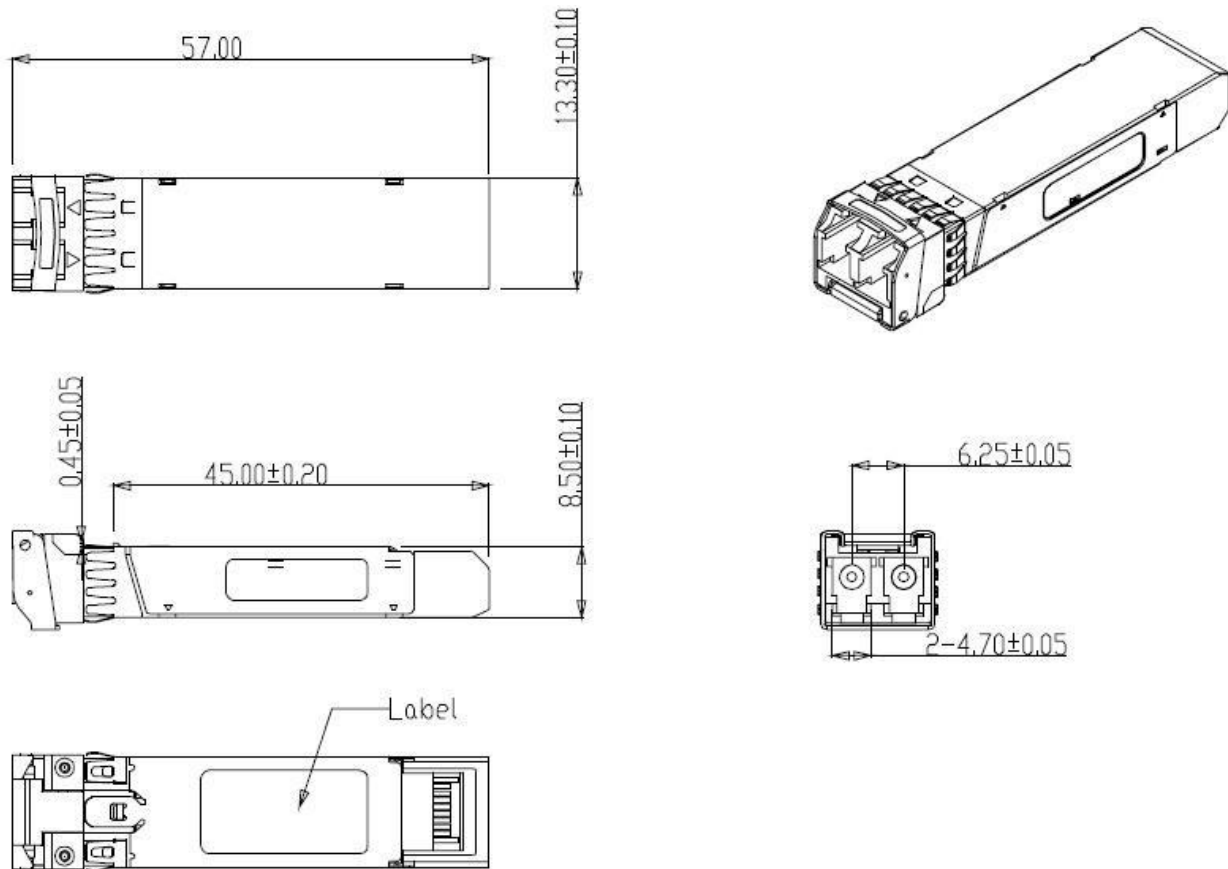

**Figure4. Mechanical Specifications**

### Regulatory Compliance

GIGALIGHT SFP+ transceiver is designed to be Class I Laser safety compliant and is certified per the following standards:

| Feature                  | Agency | Standard  | Certificate / Comments |
|--------------------------|--------|---|------------------------|
| Laser Safety             | FDA    | CDRH 21 CFR 1040 annd Laser Notice No. 50         | 1120292-000            |
| Product Safety           | UL     | UL and CUL EN60950-2:2007                         | E347511                |
| Environmental protection | SGS    | RoHS Directive 2002/95/EC                         | GZ1001008918/CHEM      |
| EMC                      | WALTEK | EN 55022:2006+A1:2007<br>EN 55024:1998+A1+A2:2003 | WT10093759-D-E-E       |

### Ordering information

| Part Number    | Product Description                             |
|----------------|---|
| NPP-55192-04CD | SFP+ ER, 11.3Gb/s, 1550nm, 40km, SMF, Duplex LC |

### References

1. "Specifications for Enhanced Small Form Factor Pluggable Module SFP+", SFF-8431, Rev 4.1, July 6, 2009.
2. "Improved Pluggable Formfactor", SFF-8432, Rev 4.2, Apr 18, 2007
3. IEEE802.3ae – 2002
4. "Diagnostic Monitoring Interface for Optical Transceivers" SFF-8472, Rev 10.3, Dec 1, 2007