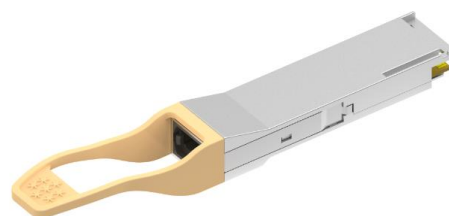

Features:

4 independent full-duplex channels
 4x25.78125Gb/s electrical interface
 QSFP28 MSA compliant
 Compliant to IEEE 802.3bm 100GBASE-SR4
 Up to 100m OM4 MMF transmission
 Operating case temperature: 0 to 70°C
 Single 3.3V power supply
 Maximum power consumption 2W
 MTP/MPO optical connector
 RoHS compliant

**Applications:**

Rack to Rack
 Data Center
 Infiniband QDR, DDR and SDR
 100G Ethernet

Part Number Ordering Information

NQS-M100-M001	QSFP28 SR4 100m optical transceiver with full real-time digital diagnostic monitoring and pull tab
---------------	--

General Description

NQS-M100-M001 is a parallel 100Gb/s Quad Small Form-factor Pluggable (QSFP28) optical module. It provides increased port density and total system cost savings. The QSFP28 full-duplex optical module offers 4 independent transmit and receive channels, each capable of 25Gb/s operation for an aggregate data rate of 100Gb/s on 100 meters of OM4 multi-mode fiber.

An optical fiber ribbon cable with an MTP/MPO connector can be plugged into the QSFP28 module receptacle. Proper alignment is ensured by the guide pins inside the receptacle. The cable usually cannot be twisted for proper channel to channel alignment. Electrical connection is achieved through an MSA-compliant 38-pin edge type connector.

The module operates by a single +3.3V power supply. LVCMOS/LVTTL global control signals, such as Module Present, Reset, Interrupt and Low Power Mode, are available with the modules. A 2-wire serial interface is available to send and receive more complex control signals, and to receive digital diagnostic information. Individual channels can be addressed and unused channels can be shut down for maximum design flexibility.

The product is designed with form factor, optical/electrical connection and digital diagnostic interface according to the QSFP28 Multi-Source Agreement (MSA). It has been designed to meet the harshest external operating conditions including temperature, humidity and EMI interference. The module offers very high functionality and feature integration, accessible via a two-wire serial interface.

Functional Description

This product converts parallel electrical input signals into parallel optical signals, by a driven Vertical Cavity Surface Emitting Laser (VCSEL) array. The transmitter module accepts electrical input signals compatible with Common Mode Logic (CML) levels. All input data signals are differential and internally terminated. The receiver module converts parallel optical input signals via a photo detector array into parallel electrical output signals. The receiver module outputs electrical signals are also voltage compatible with Common Mode Logic (CML) levels. All data signals are differential and support a data rates up to 25Gb/s per channel. Figure 1 shows the functional block diagram of this product.

A single +3.3V power supply is required to power up the module. Both power supply pins VccTx and VccRx are internally connected and should be applied concurrently. As per MSA specifications the module offers 7 low speed hardware control pins (including the 2-wire serial interface): ModSelL, SCL, SDA, ResetL, LPMode, ModPrsL and IntL.

Module Select (ModSelL) is an input pin. When held low by the host, the module responds to 2-wire serial communication commands. The ModSelL allows the use of multiple QSFP28 modules on a single 2-wire interface bus – individual ModSelL lines for each QSFP28 module must be used.

Serial Clock (SCL) and Serial Data (SDA) are required for the 2-wire serial bus communication interface and enable the host to access the QSFP28 memory map.

The ResetL pin enables a complete module reset, returning module settings to their default state, when a low level on the ResetL pin is held for longer than the minimum pulse length. During the execution of a reset the host shall disregard all status bits until the module indicates a completion of the reset interrupt. The module indicates this by posting an IntL (Interrupt) signal with the Data_Not_Ready bit negated in the memory map. Note that on power up (including hot insertion) the module should post this completion of reset interrupt without requiring a reset.

Low Power Mode (LPMode) pin is used to set the maximum power consumption for the module in order to protect hosts that are not capable of cooling higher power modules, should such modules be accidentally inserted.

Module Present (ModPrsL) is a signal local to the host board which, in the absence of a module, is normally pulled up to the host Vcc. When a module is inserted into the connector, it completes the path to ground through a resistor on the host board and asserts the signal. ModPrsL then indicates a module is present by setting ModPrsL to a "Low" state.

Interrupt (IntL) is an output pin. Low indicates a possible module operational fault or a status critical to the host system. The host identifies the source of the interrupt using the 2-wire serial interface. The IntL pin is an open collector output and must be pulled to the Host Vcc voltage on the Host board.

Transceiver Block Diagram

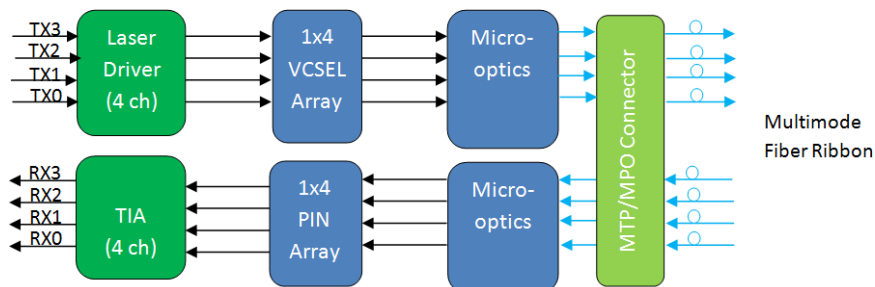
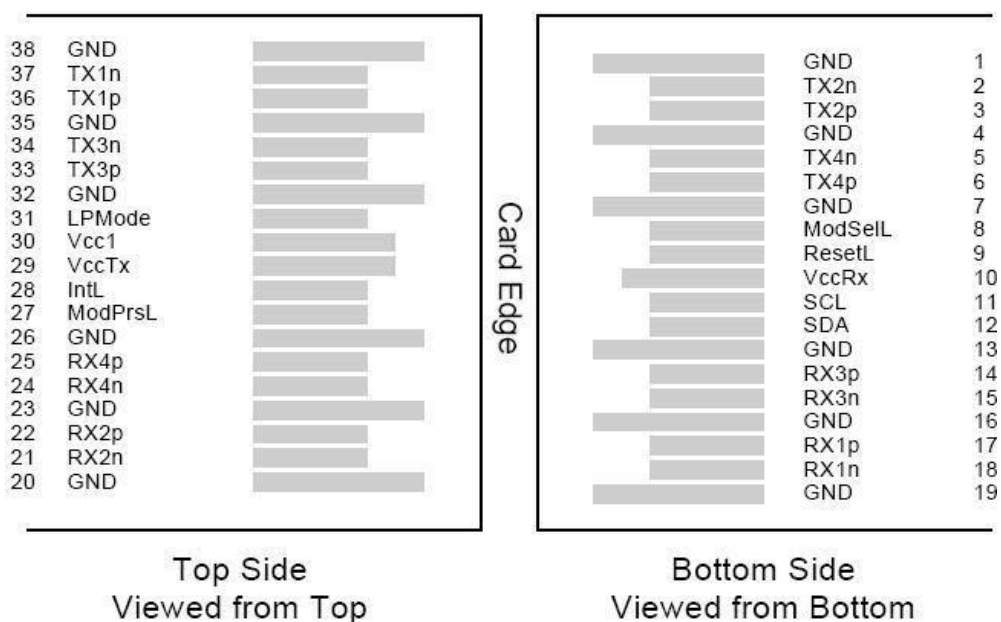

Figure 1. Transceiver Block Diagram

Pin Assignment and Description



Pin Definition

Figure 2. MSA Compliant Connector

PIN	Logic	Symbol	Name/Description	Notes
1		GND	Ground	1
2	CML-I	Tx2n	Transmitter Inverted Data Input	
3	CML-I	Tx2p	Transmitter Non-Inverted Data output	
4		GND	Ground	1
5	CML-I	Tx4n	Transmitter Inverted Data Input	
6	CML-I	Tx4p	Transmitter Non-Inverted Data output	
7		GND	Ground	1
8	LVTLL-I	ModSelL	Module Select	
9	LVTLL-I	ResetL	Module Reset	
10		VccRx	+3.3V Power Supply Receiver	2
11	LVC MOS-I/O	SCL	2-Wire Serial Interface Clock	
12	LVC MOS-I/O	SDA	2-Wire Serial Interface Data	
13		GND	Ground	
14	CML-O	Rx3p	Receiver Non-Inverted Data Output	
15	CML-O	Rx3n	Receiver Inverted Data Output	
16		GND	Ground	1
17	CML-O	Rx1p	Receiver Non-Inverted Data Output	
18	CML-O	Rx1n	Receiver Inverted Data Output	
19		GND	Ground	1
20		GND	Ground	1
21	CML-O	Rx2n	Receiver Inverted Data Output	
22	CML-O	Rx2p	Receiver Non-Inverted Data Output	
23		GND	Ground	1
24	CML-O	Rx4n	Receiver Inverted Data Output	1
25	CML-O	Rx4p	Receiver Non-Inverted Data Output	
26		GND	Ground	1
27	LVTTL-O	ModPrsL	Module Present	
28	LVTTL-O	IntL	Interrupt	
29		VccTx	+3.3 V Power Supply transmitter	2
30		Vcc1	+3.3 V Power Supply	2
31	LVTTL-I	LPMode	Low Power Mode	
32		GND	Ground	1
33	CML-I	Tx3p	Transmitter Non-Inverted Data Input	
34	CML-I	Tx3n	Transmitter Inverted Data Output	
35		GND	Ground	1
36	CML-I	Tx1p	Transmitter Non-Inverted Data Input	
37	CML-I	Tx1n	Transmitter Inverted Data Output	
38		GND	Ground	1

Notes:

1. GND is the symbol for signal and supply (power) common for QSFP28 modules. All are common within the QSFP28 module and all module voltages are referenced to this potential unless otherwise noted. Connect these directly to the host board signal common ground plane.
2. VccRx, Vcc1 and VccTx are the receiver and transmitter power suppliers and shall be applied concurrently. Recommended host board power supply filtering is shown in Figure 4 below. Vcc Rx, Vcc1 and Vcc Tx may be internally connected within the QSFP28 transceiver module in any combination. The connector pins are each rated for a maximum current of 1000mA.

Optical Interface Lanes and Assignment

Figure 3 shows the orientation of the multi-mode fiber facets of the optical connector. Table 1 provides the lane assignment.

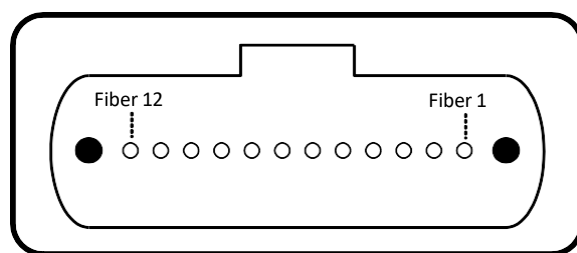

Figure 3. Outside View of the QSFP28 Module MPO Receptacle

Table 1: Lane Assignment

Fiber #	Lane Assignment
1	RX0
2	RX1
3	RX2
4	RX3
5,6,7,8	Not used
9	TX3
10	TX2
11	TX1
12	TX0

Recommended Power Supply Filter

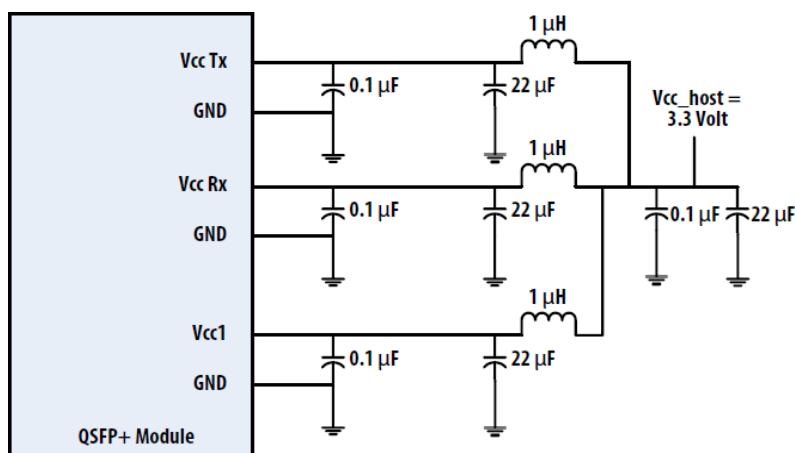

Figure 4. Recommended Power Supply Filter

Absolute Maximum Ratings

It has to be noted that the operation in excess of any individual absolute maximum ratings might cause permanent damage to this module.

Parameter	Symbol	Min	Max	Units	Note
Storage Temperature	T_S	-40	85	degC	
Operating Case Temperature	T_{OP}	0	70	degC	
Power Supply Voltage	V_{CC}	-0.5	3.6	V	
Relative Humidity (non-condensation)	RH	0	85	%	
Damage Threshold, each Lane	TH_d	3.4		dBm	

Recommended Operating Conditions and Power Supply Requirements

Parameter	Symbol	Min	Typical	Max	Units
Operating Case Temperature	T _{OP}	0		70	degC
Power Supply Voltage	V _{CC}	3.135	3.3	3.465	V
Data Rate, each Lane			25.78125	28.05	Gb/s
Control Input Voltage High		2		V _{cc}	V
Control Input Voltage Low		0		0.8	V
Link Distance (OM3 MMF)	D1			70	m
Link Distance (OM4 MMF)	D2			100	m

Electrical Characteristics

The following electrical characteristics are defined over the Recommended Operating Environment unless otherwise specified.

Parameter	Symbol	Min	Typical	Max	Units	Notes
Power Consumption				2	W	
Supply Current	I _{cc}			606	mA	
Transceiver Power-on Initialization Time				2000	ms	1
Transmitter (each Lane)						
Single Ended Input Voltage Tolerance (Note 2)		-0.3		3.6	V	
AC Common Mode Input Voltage Tolerance		15			mV	RMS
Differential Input Voltage Swing Threshold		50			mV _{pp}	LOSA Threshold
Differential Input Voltage Swing	V _{in,pp}	180		1000	mV _{pp}	
Differential Input Impedance	Z _{in}	90	100	110	Ohm	
Total Jitter				0.40	UI	
Deterministic Jitter				0.15	UI	
Receiver (each Lane)						
Single Ended Output Voltage		-0.3		4	V	
AC Common Mode Output Voltage				7.5	mV	RMS
Differential Output Voltage Swing	V _{out,pp}	300		900	mV _{pp}	
Differential Output Impedance	Z _{out}	90	100	110	Ohm	
Total Jitter				0.3	UI	
Deterministic Jitter				0.15	UI	

Notes:

1. Power-on Initialization Time is the time from when the power supply voltages reach and remain above the minimum recommended operating supply voltages to the time when the module is fully functional.
2. The single ended input voltage tolerance is the allowable range of the instantaneous input signals.

Optical Characteristics

Parameter	Symbol	Min	Typical	Max	Units	Notes
Transmitter						
Center Wavelength	λ_c	840	850	860	nm	
RMS Spectral Width	$\Delta\lambda_{rms}$			0.6	nm	
Average Launch Power, each Lane	P _{AVG}	-8.4		2.4	dBm	
Optical Modulation Amplitude (OMA), each Lane	P _{OMA}	-6.4		3.0	dBm	1

Difference in Launch Power between any Two Lanes (OMA)	P _{tx,diff}			4.0	dB	
Launch Power in OMA minus TDEC, each Lane		-7.3			dBm	
Transmitter and Dispersion Eye Closure (TDEC), each Lane				4.3	dB	
Extinction Ratio	ER	3.0			dB	
Optical Return Loss Tolerance	TOL			12	dB	
Encircled Flux		$\geq 86\%$ at 19 μm $\leq 30\%$ at 4.5 μm				
Transmitter Eye Mask Definition {X1, X2, X3, Y1, Y2, Y3}, 5×10^{-5} hits/sample		{0.3,0.38,0.45,0.35,0.41,0.5}				2
Average Launch Power OFF Transmitter, each Lane	P _{off}			-30	dBm	
Receiver						
Center Wavelength	λ_c	840	850	860	nm	
Damage Threshold, each Lane	TH _d	3.4			dBm	3
Average Receive Power, each Lane		-10.3		2.4	dBm	
Receiver Reflectance	R _R			-12	dB	
Receive Power (OMA), each Lane				3.0	dBm	
Receiver Sensitivity (OMA), each Lane	SEN			-9.2	dBm	
Stressed Receiver Sensitivity (OMA), each Lane				-5.2	dBm	4
LOS Assert	LOSA	-30			dBm	
LOS De-assert	LOSD			-12	dBm	
LOS Hysteresis	LOSH	0.5			dB	
Conditions of Stress Receiver Sensitivity Test (Note 5):						
Stressed Eye Closure (SEC), Lane under Test			4.3		dB	
Stressed Eye J2 Jitter, Lane under Test			0.39		UI	
Stressed Eye J4 Jitter, Lane under Test				0.53	UI	
OMA of each Aggressor Lane			3		dBm	
Stressed receiver eye mask definition {X1, X2, X3, Y1, Y2, Y3}		{0.28,0.5,0.5,0.33,0.33,0.4}				

Notes:

1. Even if the TDP < 0.9 dB, the OMA min must exceed the minimum value specified here.
2. See Figure 5 below.
3. The receiver shall be able to tolerate, without damage, continuous exposure to a modulated optical input signal having this power level on one lane. The receiver does not have to operate correctly at this input power.
4. Measured with conformance test signal at receiver input for BER = 5e-5.
5. Stressed eye closure and stressed eye jitter are test conditions for measuring stressed receiver sensitivity. They are not characteristics of the receiver.

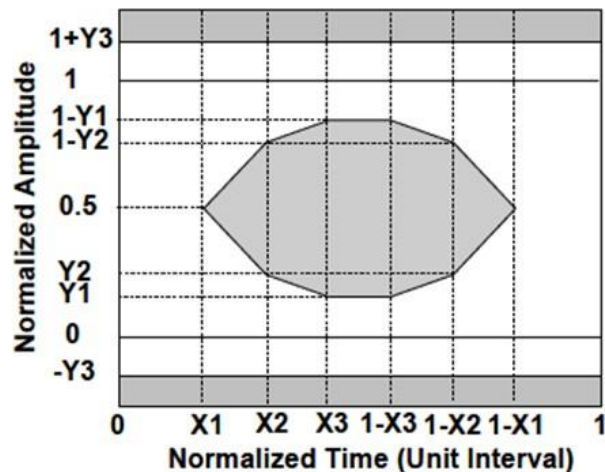

Figure 5. Eye Mask Definition

11. Digital Diagnostic Functions

The following digital diagnostic characteristics are defined over the Recommended Operating Environment unless otherwise specified. It is compliant to SFF-8436.

Parameter	Symbol	Min	Max	Units	Notes
Temperature monitor absolute error	DMI_Temp	-3	3	degC	Over operating temperature range
Supply voltage monitor absolute error	DMI_VCC	-0.15	0.15	V	Over full operating range
Channel RX power monitor absolute error	DMI_RX_Ch	-2	2	dB	1
Channel Bias current monitor	DMI_Ibias_Ch	-10%	10%	mA	Ch1~Ch4
Channel TX power monitor absolute error	DMI_TX_Ch	-2	2	dB	1

Notes:

1. Due to measurement accuracy of different single mode fibers, there could be an additional +/- 1 dB fluctuation, or a +/- 3 dB total accuracy.

12. Mechanical Dimensions

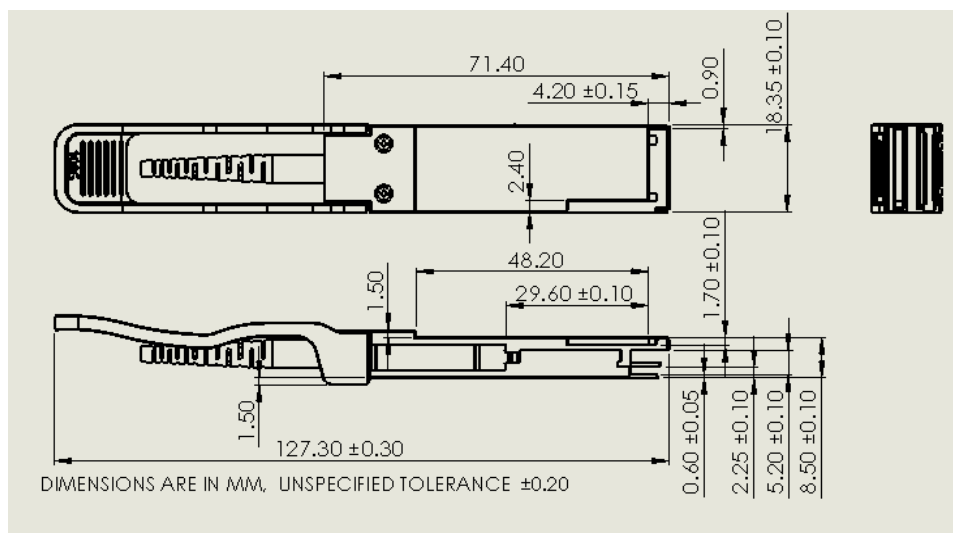

Figure 6. Mechanical Outline

ESD

This transceiver is specified as ESD threshold 1KV for SFI pins and 2KV for all others electrical input pins, tested per MIL-STD-883, Method 3015.4 /JESD22-A114-A (HBM). However, normal ESD precautions are still required during the handling of this module. This transceiver is shipped in ESD protective packaging. It should be removed from the packaging and handled only in an ESD protected environment.

Laser Safety

This is a Class 1 Laser Product according to IEC 60825-1:2007. This product complies with 21 CFR 1040.10 and 1040.11 except for deviations pursuant to Laser Notice No. 50, dated (June 24, 2007).