

10G SFP+ LR 1310nm 10km Optical Transceiver NPP-31192-LRC

Features

Supports rate from 1.25 Gb/ to 11.3 Gb/s bit rates

Optical interface compliant to IEEE 802.3ae

Electrical interface compliant to SFF-8431

Hot Pluggable

1310nm DFB transmitter, PIN photo-detector

Operating case temperature: -40 to 80 °C

Low power consumption

Applicable for 10km SMF connection

All-metal housing for superior EMI performance

Advanced firmware allow customer system encryption information to be stored in transceiver

Cost effective SFP+ solution, enables higher port densities and greater bandwidth

RoHS6 compliant (lead free) 



Applications

10GBASE-LR Ethernet

10G Fibre Channel

Product description

This 1310 nm DFB 10Gbps SFP+ transceiver is designed to transmit and receive optical data over single mode optical fiber for link length 10km.

The SFP+ 10km module electrical interface is compliant to SFI electrical specifications. The transmitter input and receiver output impedance is 100 Ohms differential. Data lines are internally AC coupled. The module provides differential termination and reduce differential to common mode conversion for quality signal termination and low EMI. SFI typically operates over 200 mm of improved FR4 material or up to about 150mm of standard FR4 with one connector.

Absolute maximum rating

These values represent the damage threshold of the module. Stress in excess of any of the individual Absolute Maximum Ratings can cause immediate catastrophic damage to the module even if all other parameters are within Recommended Operating Conditions.

Parameters	Symbol	Min.	Max.	Unit
Power Supply Voltage	V _{CC}	0	+3.6	V
Storage Temperature	T _c	-40	+85	°C
Operating Case Temperature	T _c	-40	+80	°C
Relative Humidity	RH	5	95	%
RX Input Average Power	P _{max}	-	0	dBm

Recommended operating environment

Recommended Operating Environment specifies parameters for which the electrical and optical characteristics hold unless otherwise noted.

Parameter	Symbol	Min.	Typical	Max	Unit
Power Supply Voltage	V _{CC}	3.135	3.300	3.465	V
Operating Case Temperature	T _c	0	25	70	°C

Low Speed Characteristics

Parameter	Symbol	Min.	Typical	Max	Unit
Power Consumption				1	W
TX_Fault,RX_LOS	VOL	0		0.4	V
	VOH	Host_Vcc-0.5		Host_Vcc+0.3	V
TX_DIS	VIL	-0.3		0.8	V
	VIH	2.0		VCCT+0.3	V
RS0,RS1	VIL	-0.3		0.8	V
	VIH	2.0		VCCT+0.3	V

Optical characteristics

The following optical characteristics are defined over the Recommended Operating Environment unless otherwise specified.

	Unit	Values	
Operating Reach	m	10Km	
Transmit			
Center wavelength (range)	nm	1260 -1355	
Side Mode Suppression Ratio (min)	dB	30	
Launched power			
– maximum	dBm	+0.5	
– minimum	dBm	-8.2	Notes1
– OMA	dBm	-5.2	
– OMA-TDP (min)	dBm	-6.2	
Transmitter and dispersion penalty	dB	0	Notes4
Average launch power of OFF transmitter (max)	dBm	-30	
Extinction ratio (min)	dB	3.5	Notes2
RIN12 OMA (max)	dB/Hz	-128	
Optical Return Loss Tolerance (min)	dB	12	
Receiver			
Center wavelength (range)	nm	1260~1610nm	
Receive overload (max) in average power ¹	dBm	0.5	
Receive sensitivity (min) in average power ¹	dBm	-14.4	Notes3
Receiver sensitivity (max) in OMA (footnote 2)	dBm	-12.6	Notes3
Receiver Reflectance (max)	dB	-12	
Stressed receiver sensitivity (max) in OMA ²	dBm	-10.3	
Vertical eye closure penalty (min) ³	dB	2.2	
Stressed eye jitter (min) ²	Ulp-p	0.7	
Receive electrical 3dB upper cutoff frequency (max)	GHz	12.3	
Receiver power (damage, Max)	dBm	1.5	
Notes:			
1. The optical power is launched into SMF			
2. Measured with a PRBS 2 ³¹ -1 test pattern@10.3125Gbps			
3. Measured with a PRBS 2 ³¹ -1 test pattern@10.3125Gbps BER≤10 ⁻¹²			
4. In G.652 and G.655(NDSF)			

Electrical characteristics

The following electrical characteristics are defined over the Recommended Operating Environment unless otherwise specified.

Parameter	Symbol	Min.	Typical	Max	Unit	Notes
Data Rate		1.250	10.3125	11.3	Gbps	
Power Consumption		-		1000	mW	
Transmitter						
Single Ended Output Voltage Tolerance		-0.3	-	4.0	V	
C common mode voltage tolerance		15	-	-	mV	
Tx Input Diff Voltage	VI	400		1600	mV	
Tx Fault	VoL	-0.3		0.4	V	At 0.7mA
Data Dependent Input Jitter	DDJ			0.10	UI	
Data Input Total Jitter	TJ			0.28	UI	
Receiver						
Single Ended Output Voltage Tolerance		-0.3	-	4.0	V	
Rx Output Diff Voltage	Vo	300		850	mV	
Rx Output Rise and Fall Time	Tr/Tf	30			ps	20% to 80%
Total Jitter	TJ			0.70	UI	
Deterministic Jitter	DJ			0.42	UI	

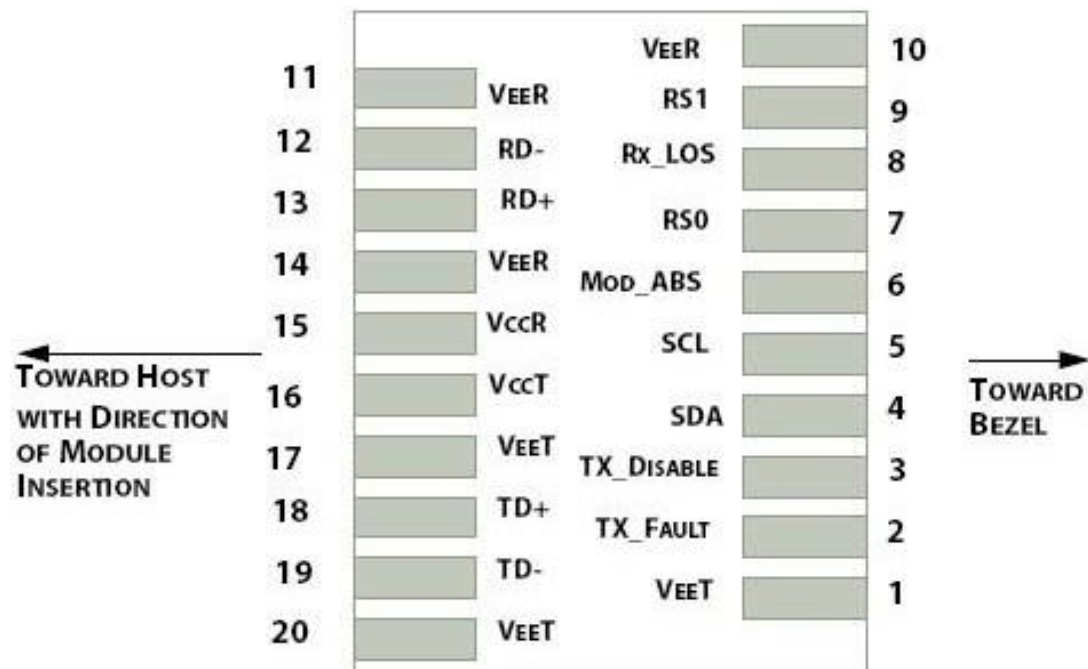

Figure 1: Interface to Host PCB

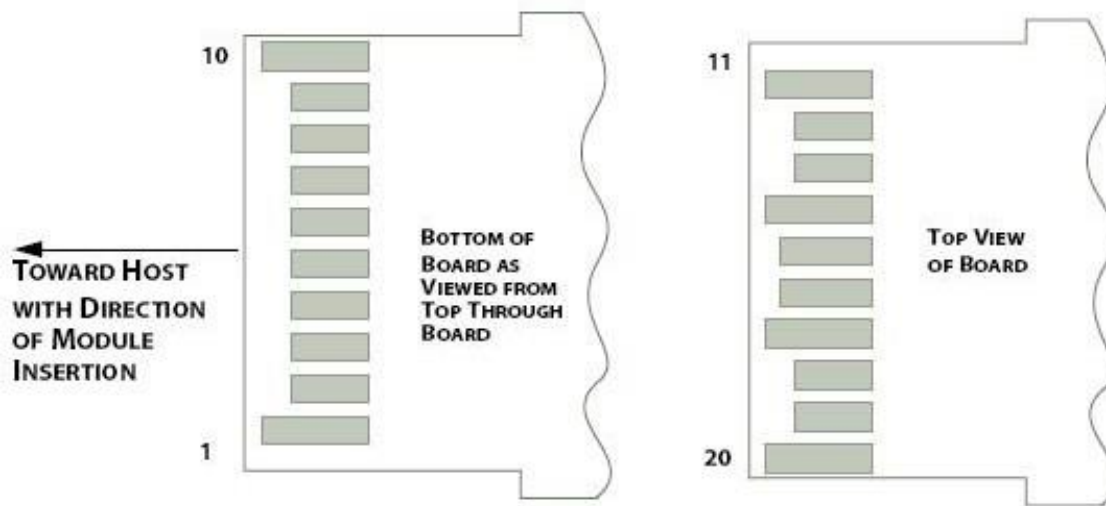

Figure 2: Module Contact Assignment

Pin definition

Pin	Symbol	Name/Description
1	VEET [1]	Transmitter Ground
2	Tx_FAULT [2]	Transmitter Fault
3	Tx_DIS [3]	Transmitter Disable. Laser output disabled on high or open
4	SDA [2]	2-wire Serial Interface Data Line
5	SCL [2]	2-wire Serial Interface Clock Line
6	MOD_ABS [4]	Module Absent. Grounded within the module
7	RS0 [5]	Rate Select 0
8	RX_LOS [2]	Loss of Signal indication. Logic 0 indicates normal operation
9	RS1 [5]	Rate Select 1
10	VEER [1]	Receiver Ground
11	VEER [1]	Receiver Ground
12	RD-	Receiver Inverted DATA out. AC Coupled
13	RD+	Receiver DATA out. AC Coupled
14	VEER [1]	Receiver Ground
15	VCCR	Receiver Power Supply
16	VCCT	Transmitter Power Supply
17	VEET [1]	Transmitter Ground
18	TD+	Transmitter DATA in. AC Coupled
19	TD-	Transmitter Inverted DATA in. AC Coupled
20	VEET [1]	Transmitter Ground

Notes:

[1] Module circuit ground is isolated from module chassis ground within the module.

[2].should be pulled up with 4.7k – 10k ohms on host board to a voltage between 3.15V and 3.6V.

[3]Tx_Disable is an input contact with a 4.7 kΩ to 10 kΩ pullup to VccT inside the module.

[4]Mod_ABS is connected to VeeT or VeeR in the SFP+ module. The host may pull this contact up to Vcc_Host with a resistor in the range 4.7 kΩ to 10 kΩ.Mod_ABS is asserted “High” when the SFP+ module is physically absent from a host slot.

[5] RS0 and RS1 are module inputs and are pulled low to VeeT with > 30 kΩ resistors in the module.

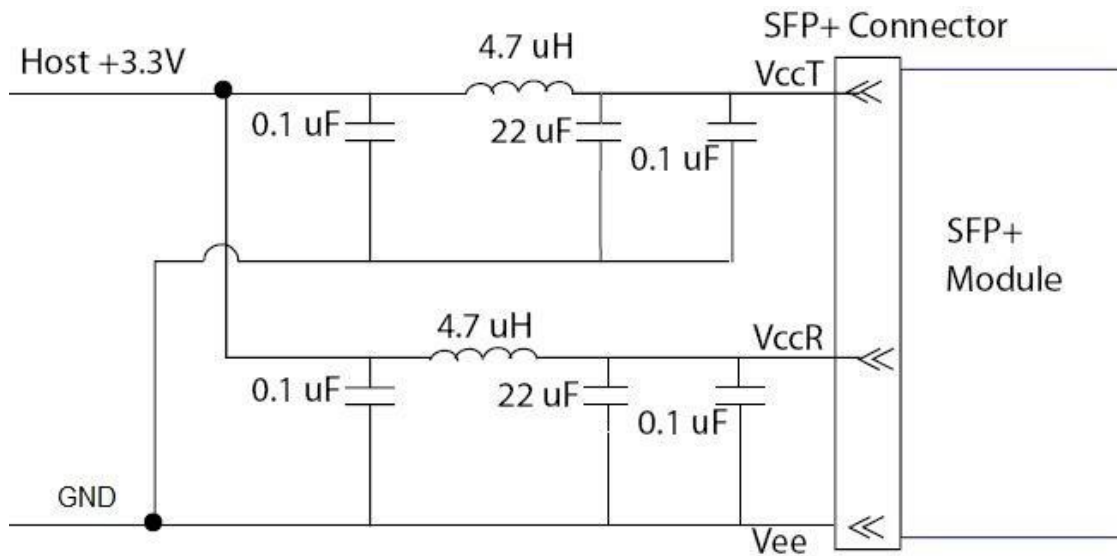

Figure3. Host Board Power Supply Filters Circuit

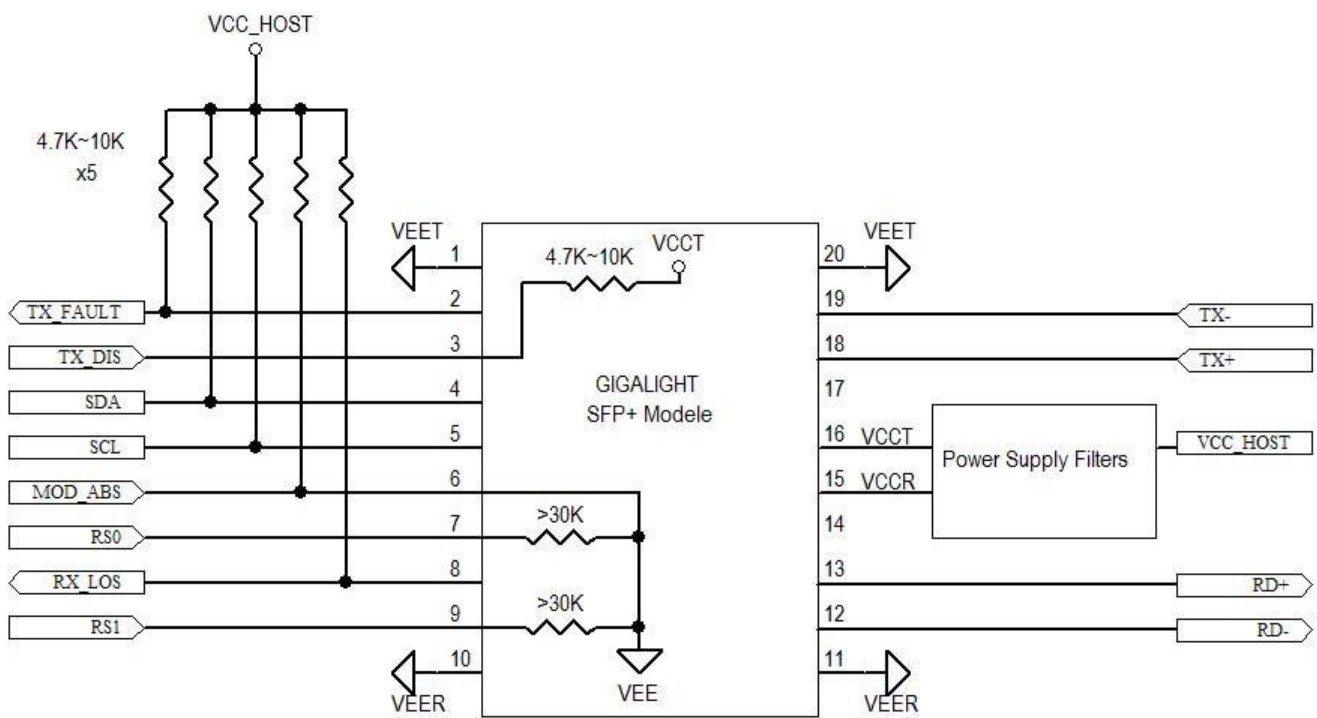

Figure4. Host-Module Interface

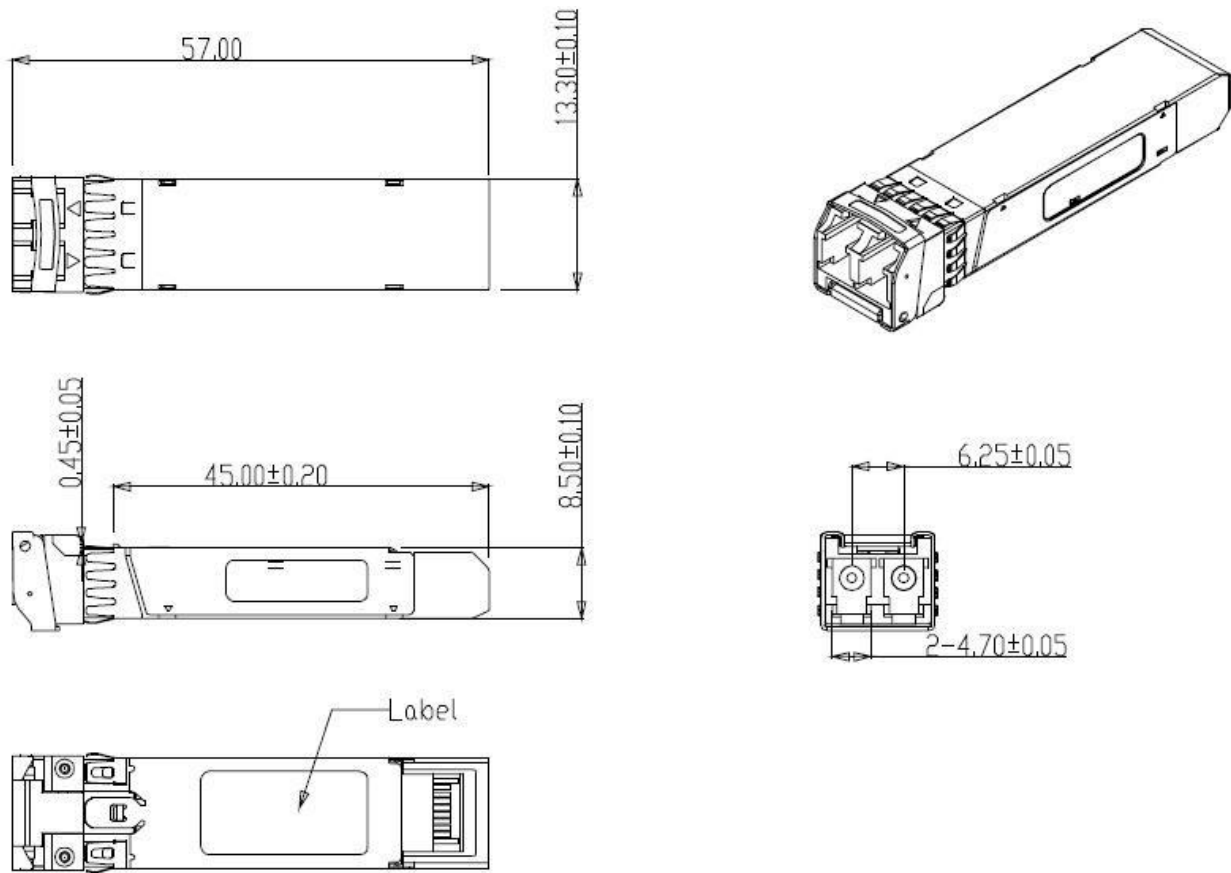

Figure5. Mechanical Specifications

Regulatory Compliance

SFP+ transceiver is designed to be Class I Laser safety compliant and is certified per the following standards:

Feature	Agency	Standard	Certificate / Comments
Laser Safety	FDA	CDRH 21 CFR 1040 annd Laser Notice No. 50	1120292-000
Product Safety	UL	UL and CUL EN60950-2:2007	E347511
Environmental protection	SGS	RoHS Directive 2002/95/EC	GZ1001008918/CHEM
EMC	WALTEK	EN 55022:2006+A1:2007 EN 55024:1998+A1+A2:2003	WT10093759-D-E-E

Ordering information

Part Number	Product Description
NPP-31192-01CT	SFP+ LR, 11.3Gb/s, 1310nm, 10km, SMF, Duplex LC, -40...+80 °C

References

1. "Specifications for Enhanced Small Form Factor Pluggable Module SFP+", SFF-8431, Rev 4.1, July 6, 2009.
2. "Improved Pluggable Formfactor", SFF-8432, Rev 4.2, Apr 18, 2007
3. IEEE802.3ae – 2002
4. "Diagnostic Monitoring Interface for Optical Transceivers" SFF-8472, Rev 10.3, Dec 1, 2007