

## 80km 1550nm SFP+ Optical Transceiver

NPP-55192-08CD

### Features

Compliant with SFF-8431, SFF-8432 and IEE802.3ae

Supports 9.8 to 11.3 Gb/s

Cooled EML transmitter and APD receiver

link length for 80km

Low Power Dissipation 1.4W Typical (Maximum: 2W)

-5°C to 70°C Operating Case Temperature

Single 3.3V power supply

Diagnostic Performance Monitoring of module temperature, supply Voltages, laser bias current, transmit optical power, receive optical power

RoHS6 compliant and lead free 



### Applications

CPRI standard

10G Ethernet

10G Fiber Channel

### Description

SFP+ 80km 1550nm Transceiver is a "Limiting module", designed for 10G Ethernet, and 10G Fiber- Channel applications. The transceiver consists of two sections: The transmitter section incorporates a cooled EML laser. And the receiver section consists of a APD photodiode integrated with a TIA. All modules satisfy class I laser safety requirements. Digital diagnostics functions are available via a 2-wire serial interface, as specified in SFF-8472, which allows real-time access to device operating parameters such as transceiver temperature, laser bias current, transmitted optical power, received optical power and transceiver supply voltage.

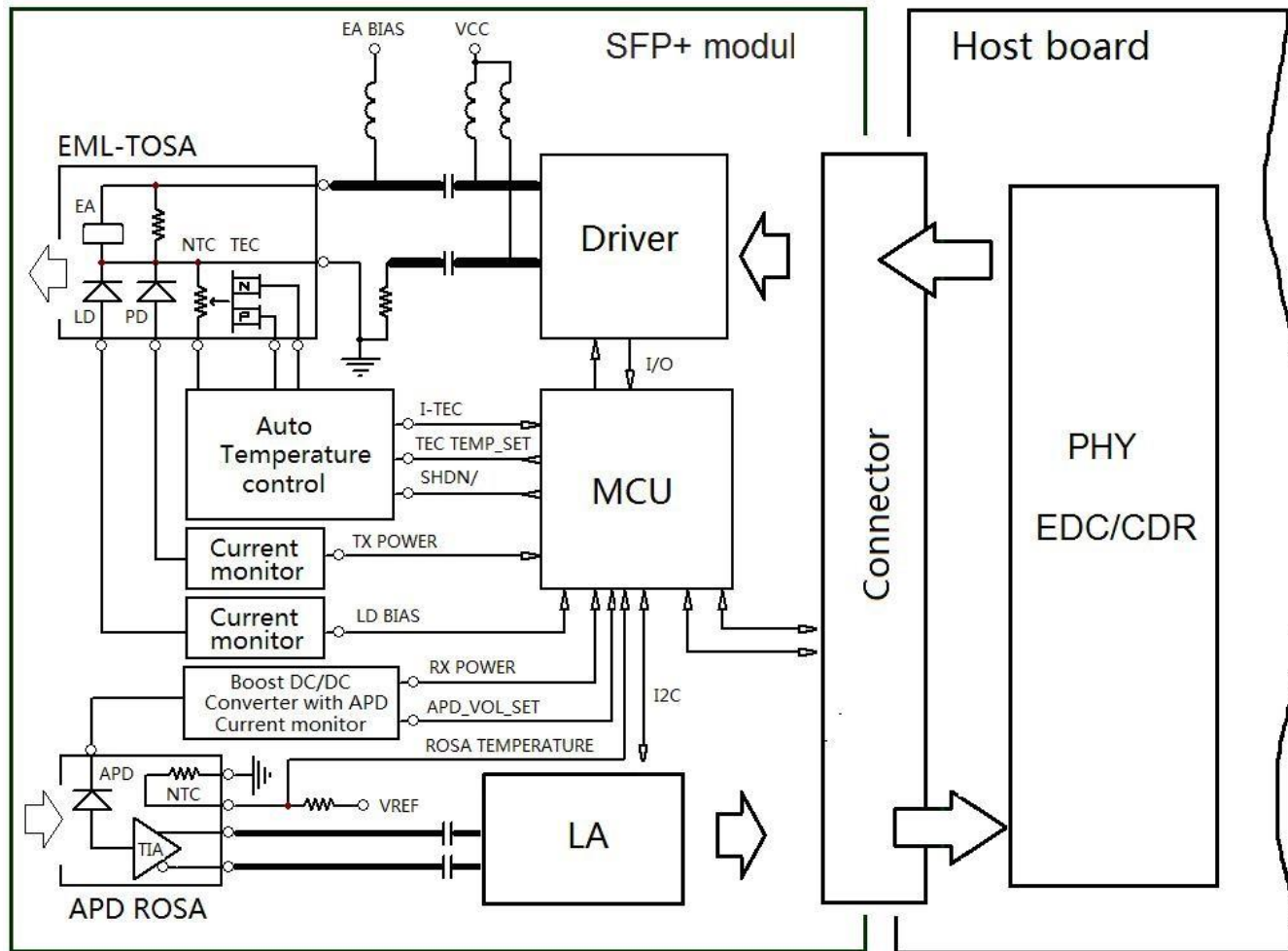

Figure1. Module Block Diagram

### Absolute Maximum Ratings

Parameter	Symbol	Min	Max	Unit
Supply Voltage	Vcc	-0.5	3.8	V
Storage Temperature	Tst	-40	85	°C
Relative Humidity	Rh	0	85	%

### Operating Conditions

Parameter	Symbol	Min	Typical	Max	Unit
Supply Voltage	Vcc	3.13	3.3	3.47	V
Supply current	Icc	-	420	610	mA
Operating Case temperature	Tca	-5	-	70	°C
Module Power Dissipation	Pm	-	1.4	2	W

## Transmitter Specifications – Optical

Parameter	Symbol	Min	Typical	Max	Unit
Center Wavelength	c	1530		1565	nm
Spectral Width (-20dB)	$\Delta\lambda_{20}$	-	-	0.3	nm
Average Optical Power [2]	Po	0	-	+4	dBm
Side Mode Suppression Ratio	SMSR	30	-	-	dB
Optical Transmit Power (disabled)	PTX_DISABLE	-	-	-30	dBm
Extinction Ratio	ER	8.2	-	-	dB
Relative Intensity Noise	RIN	-	-	-128	dB/Hz
Optical Return Loss Tolerance	Orl	-	-	21	dB

## Receiver Specifications – Optical

Parameter	Symbol	Min	Typical	Max	Unit	
Input Operating Wavelength	$\lambda$	1260	-	1620	nm	
Receiver Sensitivity (9.95–10.3)	R <sub>sen1</sub>	-	-	-24	dBm	2
Receiver Sensitivity(80KM)	R <sub>sen2</sub>			-24	dBm	2
Maximum Input Power	RX-overload	-7	-		dBm	
Loss of Signal Asserted	Lsa	-34	-	-	dBm	
LOS De-Asserted	Lda	-	-	-26	dBm	
LOS Hysteresis	Lh	0.5	-	-	dB	

### Notes:

[1] Measured with conformance test signal for BER =  $10^{-12}$ . The stressed sensitivity values in the table are for system level BER measurements which include the effects of CDR circuits. It is recommended that at least 0.4 dB additional margin be allocated if component level measurements are made without the effects of CDR circuits.

[2] Measured with worst ER=8.2dB;  $2^{31} - 1$  PRBS. BER <  $1E^{-12}$

## Transmitter Specifications – Electrical

Parameter	Symbol	Min	Typical	Max	Unit
Data Rate	Mra	9.8		11.3168	Gbps
Input differential impedance	Rim	-	100	-	$\Omega$
Differential data Input	VtxDIFF	120	-	850	mV
Transmit Disable Voltage	VD	2.0	-	Vcc3+0.3	V
Transmit Enable Voltage	Ven	0	-	+0.8	V
Transmit Disable Assert Time	Vn	-	-	100	us

## Receiver Specifications – Electrical

Parameter	Symbol	Min	Typical	Max	Unit
Data Rate	Mra	9.95		10.3	Gbps
Differential Output Swing	Vout P-P	350	-	850	mV
Rise/Fall Time	Tr / Tf	24	-	-	ps
Loss of Signal –Asserted	VOH	2	-	Vcc3+0.3-	V
Loss of Signal –Negated	VOL	0	-	+0.4	V

## Digital Diagnostic Functions

Parameter	Symbol	Min.	Max	Unit	Notes
<b>Accuracy</b>					
Transceiver Temperature	DMI_Temp	-3	+3	degC	Over operating temp
TX Output optical power	DMI_TX	-3	+3	dB	
RX Input optical power	DMI_RX	-3	+3	dB	-3dBm to -12dBm range
Transceiver Supply voltage	DMI_VCC	-0.08	+0.08	V	Full operating range
Bias current monitor	DMI_Ibias	-10%	10%	mA	
<b>Dynamic Range Accuracy</b>					
Transceiver Temperature	DMI_Temp	-5	70	degC	
TX Output optical power	DMI_TX	0	+4	dBm	
RX Input optical power	DMI_RX	-26	-7	dBm	
Transceiver Supply voltage	DMI_VCC	3.0	3.6	V	
Bias current monitor	DMI_Ibias	0	100	mA	

## Pin Descriptions

Pin	Symbol	Name/Description
1	VEET [1]	Transmitter Ground
2	Tx_FAULT [2]	Transmitter Fault
3	Tx_DIS [3]	Transmitter Disable. Laser output disabled on high or open
4	SDA [2]	2-wire Serial Interface Data Line
5	SCL [2]	2-wire Serial Interface Clock Line
6	MOD_ABS [4]	Module Absent. Grounded within the module
7	RS0 [5]	Rate Select 0
8	RX_LOS [2]	Loss of Signal indication. Logic 0 indicates normal operation
9	RS1 [5]	Rate Select 1
10	VEER [1]	Receiver Ground
11	VEER [1]	Receiver Ground
12	RD-	Receiver Inverted DATA out. AC Coupled
13	RD+	Receiver DATA out. AC Coupled
14	VEER [1]	Receiver Ground
15	VCCR	Receiver Power Supply
16	VCCT	Transmitter Power Supply
17	VEET [1]	Transmitter Ground
18	TD+	Transmitter DATA in. AC Coupled
19	TD-	Transmitter Inverted DATA in. AC Coupled
20	VEET [1]	Transmitter Ground

### Notes:

[1] Module circuit ground is isolated from module chassis ground within the module.

[2].should be pulled up with 4.7k – 10k ohms on host board to a voltage between 3.15V and 3.6V.

[3]Tx\_Disable is an input contact with a 4.7 kΩ to 10 kΩ pullup to VccT inside the module.

[4] Mod\_ABS is connected to VeeT or VeeR in the SFP+ module. The host may pull this contact up to Vcc\_Host with a resistor in the range 4.7 kΩ to 10 kΩ. Mod\_ABS is asserted “High” when the SFP+ module is physically absent from a host slot.

[5] RS0 and RS1 are module inputs and are pulled low to VeeT with > 30 kΩ resistors in the module.

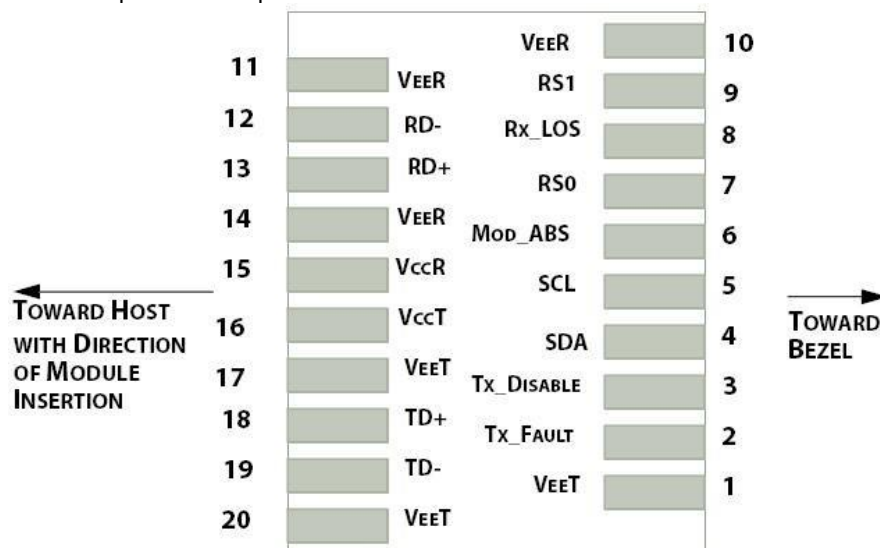

Figure2.Electrical Pin-out Details

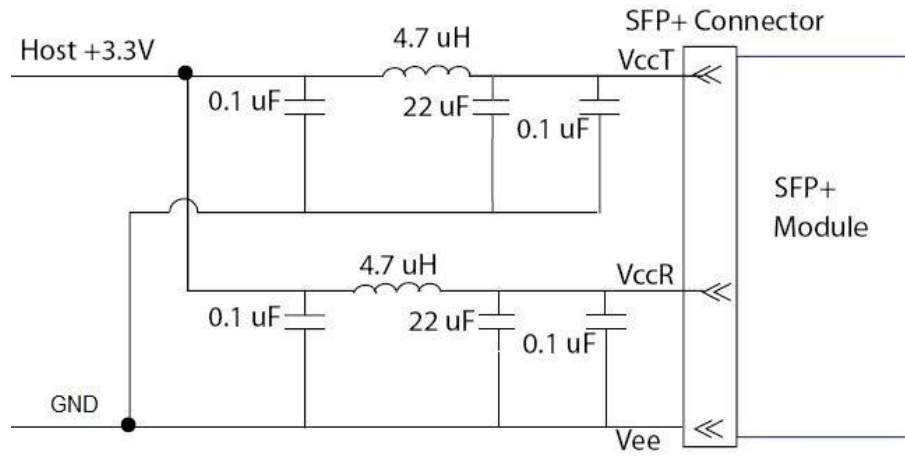

Figure3. Host Board Power Supply Filters Circuit

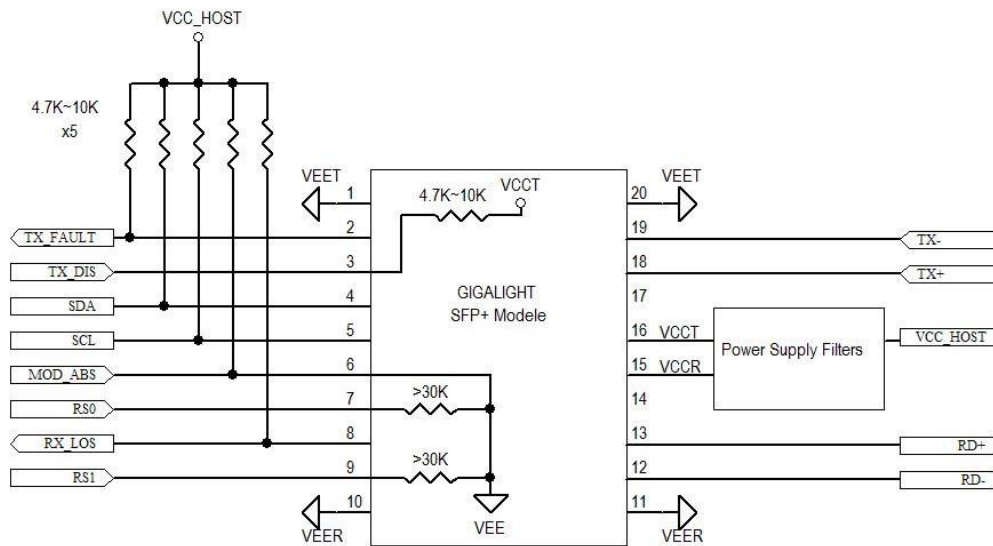
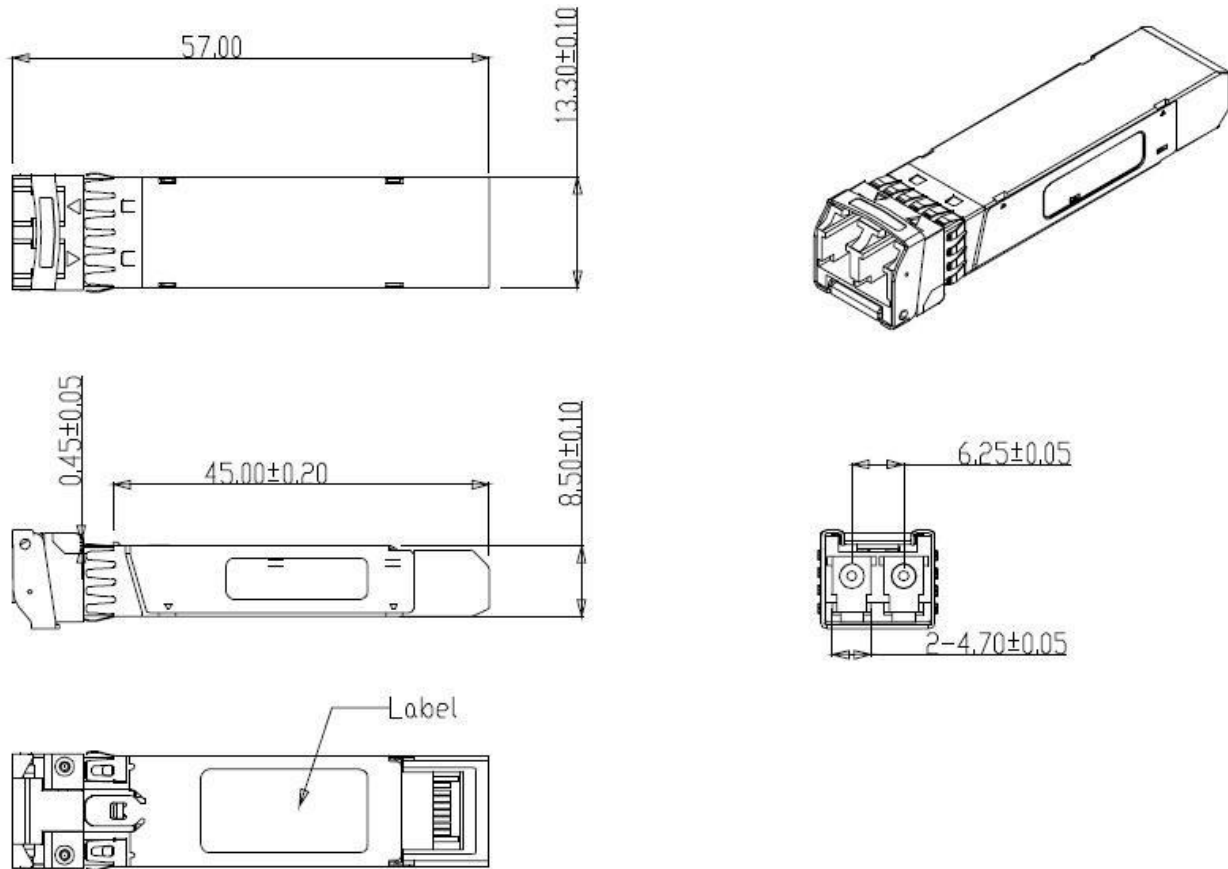

Figure4. Host-Module Interface



**Figure5. Mechanical Specifications**

### Regulatory Compliance

SFP+ transceiver is designed to be Class I Laser safety compliant and is certified per the following standards:

Feature	Agency	Standard	Certificate / Comments
Laser Safety	FDA	CDRH 21 CFR 1040 annd Laser Notice No. 50	1120292-000
Product Safety	UL	UL and CUL EN60950-2:2007	E347511
Environmental protection	SGS	RoHS Directive 2002/95/EC	GZ1001008918/CHEM
EMC	WALTEK	EN 55022:2006+A1:2007 EN 55024:1998+A1+A2:2003	WT10093759-D-E-E

### Ordering information

Part Number	Product Description
NPP-55192-08CD	10Gbps, 1550nm SFP+, 80km, -5°C ~ +70°C

### References

1. "Specifications for Enhanced Small Form Factor Pluggable Module SFP+", SFF-8431, Rev 4.1, July 6, 2009.
2. "Improved Pluggable Formfactor", SFF-8432, Rev 4.2, Apr 18, 2007
3. IEEE802.3ae – 2002

4. "Diagnostic Monitoring Interface for Optical Transceivers" SFF-8472, Rev 10.3, Dec 1,2007