

Features:

- UP to 25.78Gb/s bit rates
- Hot-Pluggable SFP28 footprint
- Duplex LC connector
- 1310nm DFB laser transmitter
- Up to 10km on 9/125m SMF
- 2-wire interface for management specifications compliant with SFF 8472 digital diagnostic monitoring interface for optical transceivers
- Power Supply: +3.3V
- Operating case temperature Range:
- Commercial: 0~ 70°C
- Industrial: -40~ 85°C
- RoHS compliant



Applications:

- 25GE LR
- eCPRI&CPRI

Part Number Ordering Information

NSS-S25-L10	SFP28 10km optical transceiver with full real-time digital diagnostic monitoring, 0~70°C, 25GE
NSS-S25-L10I	SFP28 10km optical transceiver with full real-time digital diagnostic monitoring, -40~85°C, 25GE

Description:

NSS-S25-L10 SFP28 transceivers are designed for use in Ethernet links up to 25.78 Gb/s data rate and up to 10 km link length. They are compliant SFF-8472 , and compatible with SFF-8432 and applicable portions of SFF-8431. The product is RoHS compliant and lead-free per Directive 2011/96/EU.

Absolute Maximum Ratings

Parameter	Symbol	Min.	Typical	Max.	Unit	Note
Storage Temperature	T _S	-40		+85	°C	
Case Operating Temperature	T _c	0		+70	°C	Commercial
Case Operating Temperature	T _c	-40		+85	°C	Industrial
Maximum Supply Voltage	V _{cc}	0		3.6	V	
Relative Humidity(Non-condensing)	RH	0		85	%	

Electrical Characteristics

Parameter	Symbol	Min.	Typical	Max.	Unit	Note
Supply Voltage	V _{cc}	3.15		3.46	V	
Supply Current	I _{cc}			400	mA	
Power Consumption	P			1.3	W	
Data Rate	R	-	25.78		Gb/s	
Fiber Length	L			10	Km	
Transmitter Section:						
Input differential impedance	R _{in}		100		Ω	1
Differential input voltage swing	V _{in,pp}	180		700	mV	2
Transmit Disable Voltage	V _D	2		V _{cc}	V	3
Transmit Enable Voltage	V _{EN}	V _{ee}		V _{ee} +0.8	V	
Receiver Section:						
Single Ended Output Voltage Tolerance	V	-0.3		4	V	
Rx Output Diff Voltage	V _O	185		800	mV	
LOS Fault	V _{LOS fault}	2		V _{ccHOST}	V	4
LOS Normal	V _{LOS norm}	V _{ee}		V _{ee} +0.8	V	4

Note:

1. Connected directly to TX data input pins. AC coupling from pins into laser driver IC.
2. Per SFF-8431 Rev 3.0
3. Into 100 ohms differential termination.
4. LOS is an open collector output. Should be pulled up with 4.7k – 10kΩ on the host board. Normal operation is logic 0; loss of signal is logic 1. Maximum pull-up voltage is 5.5V.

Optical Characteristics

Parameter	Symbol	Min.	Typical	Max.	Unit	Note
Transmitter Section:						
Center Wavelength	λ _t	1295		1325	nm	
spectral width(-20dB)	Δλ			1	nm	
Average Optical Power	P _{avg}	-7.0		+2.0	dBm	
Laser Off Power	P _{off}			-30	dBm	
Side Mode Suppression Ratio		30				
Extinction Ratio	ER	3.5			dB	
Optical Return Loss Tolerance				-12	dB	
Receiver Section:						
Center Wavelength	λ _r	1260		1370	nm	
Receiver Sensitivity	Sen			-12	dBm	1
Los Assert	LOS _A	-30		-	dBm	
Los Dessert	LOS _D			-14	dBm	
Los Hysteresis	LOS _H	0.5			dB	
Overload		2			dBm	

Note:

1. Measured with a PRBS 2³¹-1 test pattern, @25.78Gb/s, BER<5E-5.

Digital Diagnostic Specifications

Parameter	Symbol	Units	Min	Max	Accuracy
Transceiver Temperature	Temp	°C	-40	+85	±5°C
Transceiver Supply Voltage	Voltage	V	3.15	3.45	±3%
Transmitter Bias Current	Bias	mA	0	35	±10%
Transmitter Output Power	Tx-Power	dBm	-7	+2	±3dB
Receiver Average Optical Input Power	Rx-Power	dBm	-12	-3	±3dB

Transceiver Block Diagram

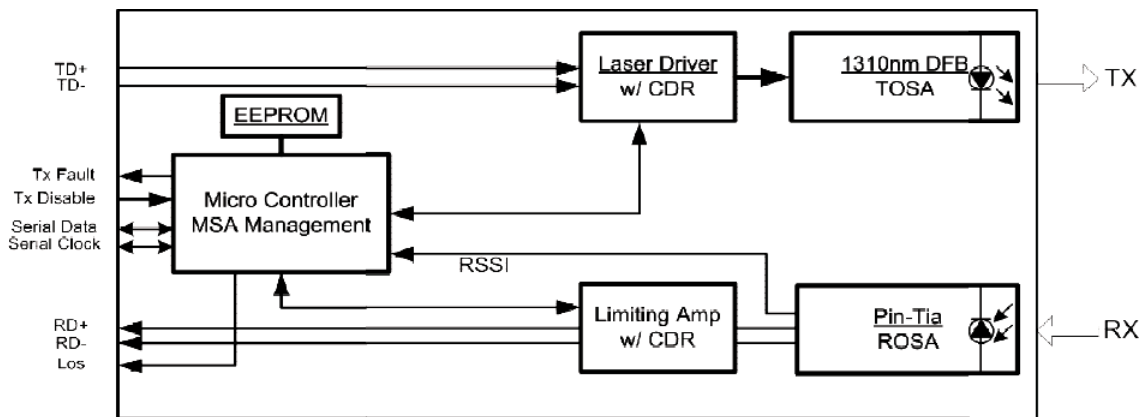

Pin Function Definitions

PIN #	Name	Function	Notes
1	VeeT	Module transmitter ground	1
2	Fault	Module transmitter Fault	2
3	Disable	Transmitter Disable; Turns off transmitter laser output	3
4	SDL	2 wire serial interface data input/output (SDA)	4
5	SCL	2 wire serial interface clock input (SCL)	4
6	MOD-ABS	Module Absent, connect to VeeR or VeeT in the module	2
7	RS0	Rate select0: module inputs and are pulled low to VeeT with > 30 kΩ resistors in the module.	
8	LOS	Receiver Loss of Signal Indication	
9	RS1	Rate select1: module inputs and are pulled low to VeeT with > 30 kΩ resistors in the module.	
10	VeeR	Module receiver ground	1
11	VeeR	Module receiver ground	1
12	RD-	Receiver inverted data out put	
13	RD+	Receiver non-inverted data out put	
14	VeeR	Module receiver ground	1
15	VccR	Module receiver 3.3V supply	
16	VccT	Module transmitter 3.3V supply	
17	VeeT	Module transmitter ground	1
18	TD+	Transmitter non-inverted data out put	
19	TD-	Transmitter inverted data out put	
20	VeeT	Module transmitter ground	1

Note:

1. The module ground pins shall be isolated from the module case.
2. This pin is an open collector/drain output pin and shall be pulled up with 4.7K-10Kohms to Host_Vcc on the host board.
3. This pin shall be pulled up with 4.7K-10Kohms to VccT in the module.
4. This pin is an open collector/drain output pin and shall be pulled up with 4.7K-10Kohms to Host_Vcc on the host board.

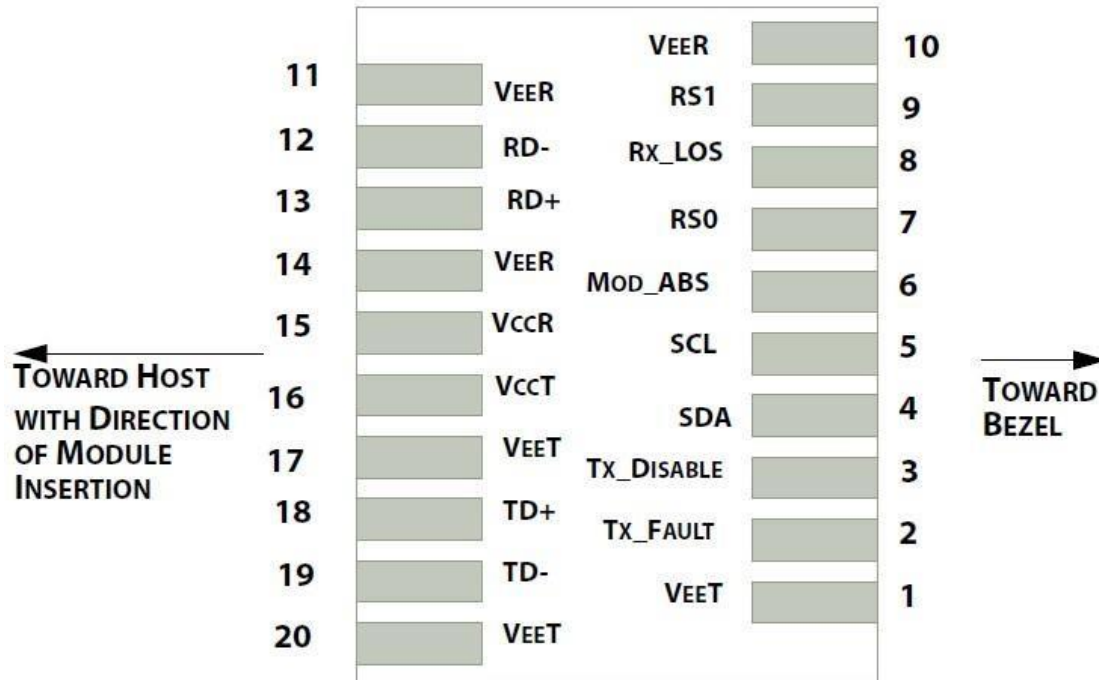
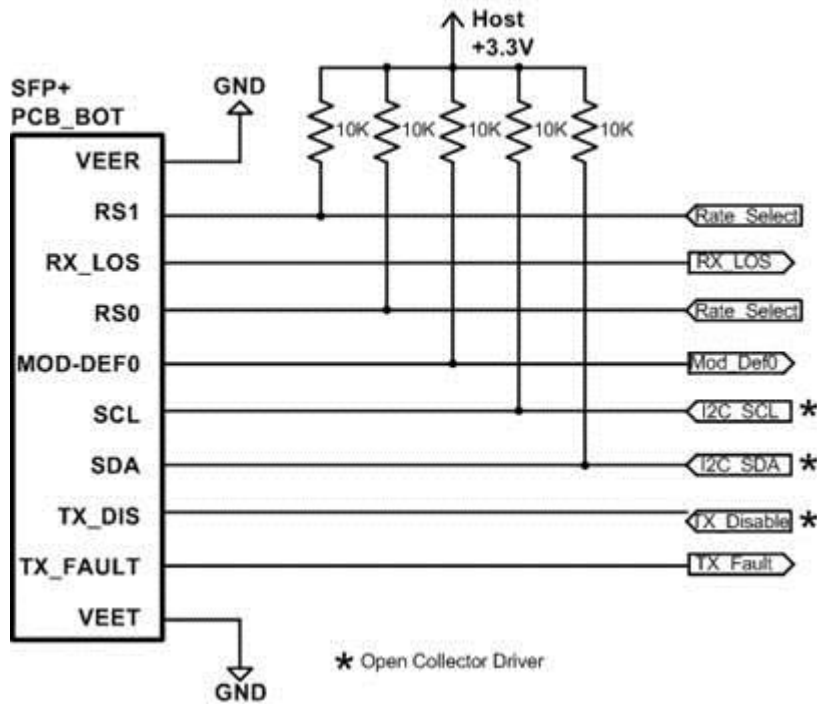
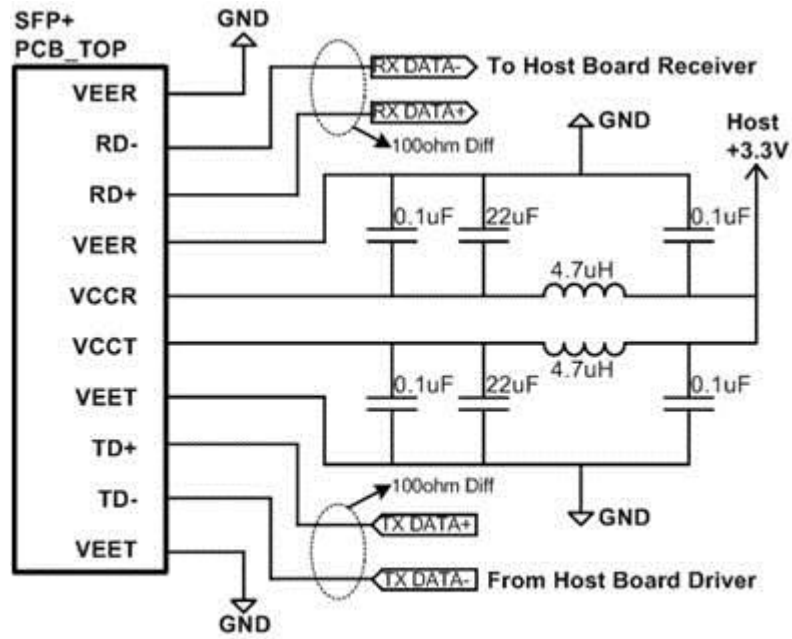

Diagram of Host Board Connector Block Pin Numbers and Names

Recommended Circuit:



Recommended High-speed Interface Circuit

Mechanical Dimensions:

