

Features:

UP to 25.78Gb/s bi-directional data links

Hot-Pluggable SFP28 footprint

Duplex LC connector

CWDM EML laser transmitter

Up to 10km on 9/125m SMF

Power Supply: +3.3V

Operating case temperature Range: 0~ 70°C

RoHS compliant

2-wire interface for management specifications compliant with SFF 8472 digital diagnostic monitoring

interface for optical transceivers



Applications:

25GE LR

eCPRI&CPRI

Part Number Ordering Information

NSS-S25-L10C-xx	25GE, SFP28 LR 10km CWDM 1471~1571nm optical transceiver, 0~70°C, XX:47,49,51,53,55,57
-----------------	--

Description:

NSS-S25-L10C-xx SFP28 transceivers are designed for use in Ethernet links up to 25.78 Gb/s data rate and up to 10 km link length. They are compliant SFF-8472, and compatible with SFF-8432 and applicable portions of SFF-8431. The product is RoHS compliant and lead-free per Directive 2011/96/EU.

Pin Function Definitions

PIN #	Name	Function	Notes
1	VeeT	Module transmitter ground	1
2	Fault	Module transmitter Fault	2
3	Disable	Transmitter Disable; Turns off transmitter laser output	3
4	SDL	2 wire serial interface data input/output (SDA)	4
5	SCL	2 wire serial interface clock input (SCL)	4
6	MOD-ABS	Module Absent, connect to VeeR or VeeT in the module	2
7	RS0	Rate select0: module inputs and are pulled low to VeeT with > 30 kΩ resistors in the module.	
8	LOS	Receiver Loss of Signal Indication	
9	RS1	Rate select1: module inputs and are pulled low to VeeT with > 30 kΩ resistors in the module.	
10	VeeR	Module receiver ground	1
11	VeeR	Module receiver ground	1
12	RD-	Receiver inverted data out put	
13	RD+	Receiver non-inverted data out put	
14	VeeR	Module receiver ground	1
15	VccR	Module receiver 3.3V supply	
16	VccT	Module transmitter 3.3V supply	
17	VeeT	Module transmitter ground	1
18	TD+	Transmitter non-inverted data out put	
19	TD-	Transmitter inverted data out put	
20	VeeT	Module transmitter ground	1

Note:

1. The module ground pins shall be isolated from the module case.
2. This pin is an open collector/drain output pin and shall be pulled up with 4.7K-10Kohms to Host_Vcc on the host board.
3. This pin shall be pulled up with 4.7K-10Kohms to VccT in the module.
4. This pin is an open collector/drain output pin and shall be pulled up with 4.7K-10Kohms to Host_Vcc on the host board.

Diagram of Host Board Connector Block Pin Numbers and Names

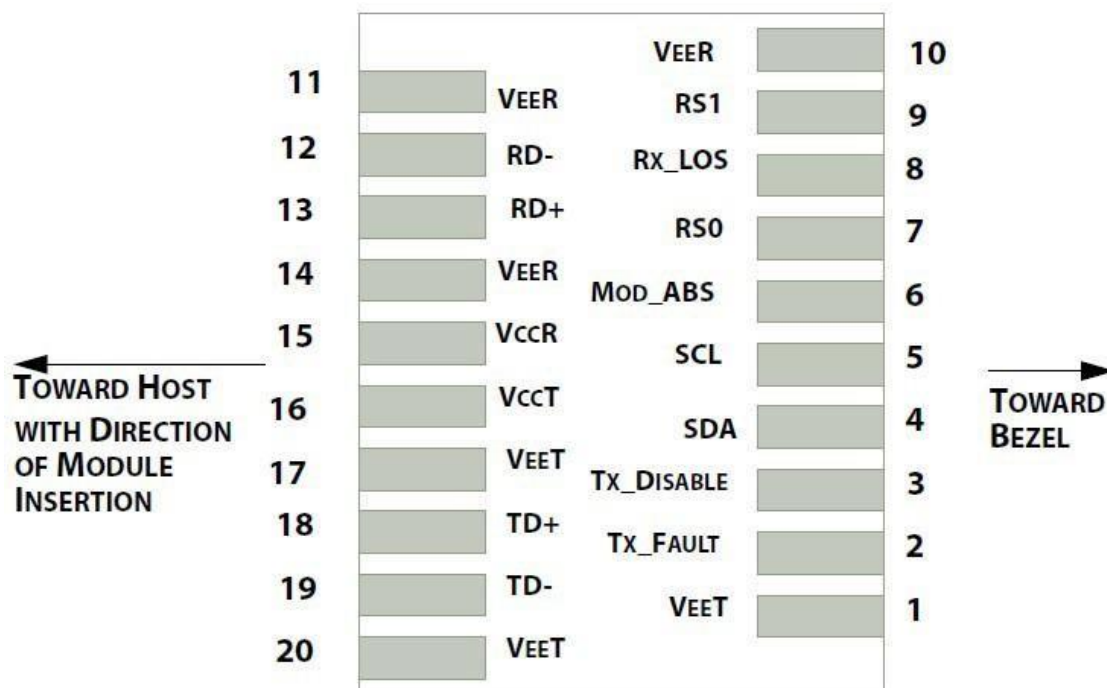

Absolute Maximum Ratings

Parameter	Symbol	Min.	Typical	Max.	Unit
Storage Temperature	T_S	-40		+85	°C
Case Operating Temperature	T_A	0		+70	°C
Maximum Supply Voltage	Vcc	0		3.6	V
Relative Humidity(Non-condensing)	RH	0		85	%

Electrical Characteristics

Parameter	Symbol	Min.	Typical	Max.	Unit	Note
Supply Voltage	Vcc	3.15		3.46	V	
Supply Current	Icc			600	mA	
Power Consumption	P			2	W	
Data Rate	R	-	25.8		Gb/s	
Fiber Length	L			10	KM	
Transmitter Section:						
Input differential impedance	R_{in}		100		Ω	1
Differential input voltage swing	$V_{in,pp}$	180		450	mV	2
Transmit Disable Voltage	V_D	2		Vcc	V	3
Transmit Enable Voltage	VEN	Vee		$V_{ee}+0.8$	V	
Receiver Section:						
Single Ended Output Voltage Tolerance	V	-0.3		4	V	
Rx Output Diff Voltage	V_o	180		450	mV	
LOS Fault	V_{LOS} fault	2		$V_{cc}HOS_T$	V	4
LOS Normal	V_{LOS} norm	Vee		$V_{ee}+0.8$	V	4

Note:

1. Connected directly to TX data input pins. AC coupling from pins into laser driver IC.
2. Per SFF-8431 Rev 3.0
3. Into 100 ohms differential termination.
4. LOS is an open collector output. Should be pulled up with 4.7k – 10k Ω on the host board. Normal operation is logic 0; loss of signal is logic 1. Maximum pull-up voltage is 5.5V.

Optical Characteristics

Parameter	Symbol	Min.	Typical	Max.	Unit	Note
Transmitter Section:						
Center Wavelength	λ_t	$\lambda - 6.5$	λ	$\lambda + 6.5$	nm	
spectral width(-20dB)	$\Delta\lambda$			1	nm	
Average Optical Power	P_{avg}	-3.0		+6.0	dBm	
Laser Off Power	P_{off}			-30	dBm	
Side Mode Suppression Ratio		30				

Extinction Ratio	ER	5			dB	
Optical Return Loss Tolerance				-12	dB	
Receiver Section:						
Center Wavelength	λ_r	1260		1610	nm	
Receiver Sensitivity	Sen			-12	dBm	1
Los Assert	LOS _A	-30			dBm	
Los Dessert	LOS _D			-13	dBm	
Los Hysteresis	LOS _H	0.5			dB	
Overload		2			dBm	

Note:

1. Measured with a PRBS 2³¹-1 test pattern, @25.78Gb/s, BER<5E-5.

Timing Characteristics

Parameter	Symbol	Min.	Typical	Max.	Unit
TX_Disable Assert Time	t_off			100	us
TX_Disable Negate Time	t_on			2	ms
Time to Initialize 2-wire interface	t_2w_start_up			300	ms
Time to Initialize	t_start_up			300	ms
Time to Initialize cooled module and time to power up a cooled module to Power level II	t_start_up_cooled			90	s
Time to Power Up to Level II	t_power_level2			300	ms
Time to Power Down from Level II	t_power_down			300	ms
Tx_Fault assert	Tx_Fault_on			1	ms
Tx_Fault assert for cooled module	Tx_Fault_on_cooled			50	ms
TX_FAULT Reset	t_reset	10			us
Rx_LOS assert delay	t_los_on			100	us
Rx_LOS negate delay	t_los_off			100	us

Digital Diagnostic Specifications

Parameter	Symbol	Units	Min	Max	Accuracy
Transceiver Temperature	Temp	°C	0	+70	±5°C
Transceiver Supply Voltage	Voltage	V	3.15	3.45	±3%
Transmitter Bias Current	Bias	mA	0	35	±10%
Transmitter Output Power	Tx-Power	dBm	-3	+6	±3dB
Receiver Average Optical Input Power	Rx-Power	dBm	-12	+1	±3dB

Transceiver Block Diagram

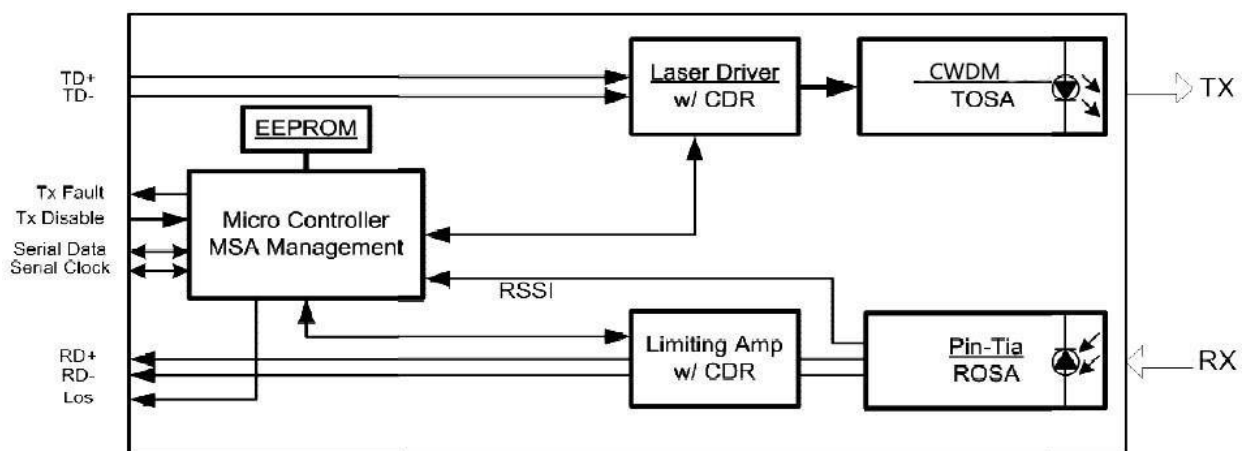

Recommended Circuit:

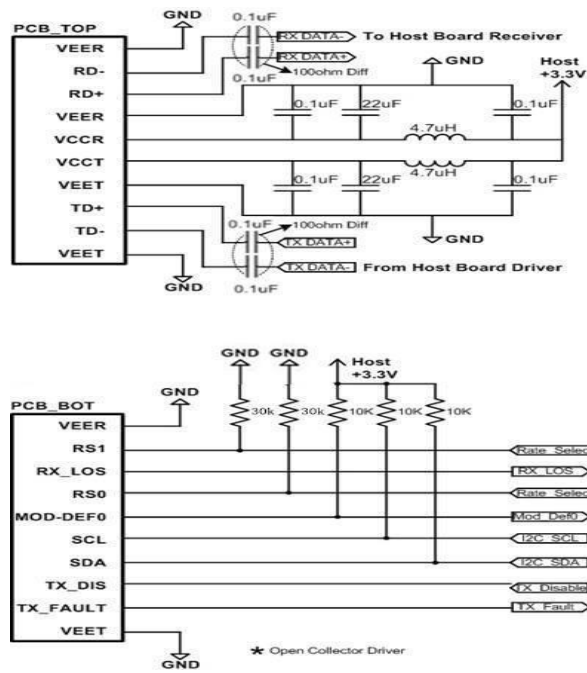

Recommended High-speed Interface Circuit

Mechanical Dimensions:

