

**400G QSFP56-DD DR4 500m Optical Transceiver Module****NQS-S400-L005****Features**

QSFP-DD MSA rev 5.1 and CMIS rev4p0 compliant  
Compliant to 802.3bs 400GBASE-DR4  
8x53.125Gbit/s PAM4 electrical interface(400GAUI-8)  
4x106.25Gbps (53.125GBd PAM4) Optics architecture  
Power consumption <10W  
Maximum link length of 500m G.652 SMF with KP-FEC  
MPO receptacles  
Built-in digital diagnostic functions  
Operating case temperature 0°C to +70°C  
3.3V power supply voltage  
RoHS compliant (lead free)

**Applications**

IEEE 802.3bs 400GBASE-DR4  
Data center network

**Description**

NQS-S400-L005 is a transceiver module designed for 500m optical communication applications, and it is compliant to QSFP-DD MSA, IEEE 802.3bs protocol and 400GAUI-8 standards. The 425 Gigabit signal is carried over four parallel lanes by one wavelength per lane. This module can convert 8-channel 53.125 Gbit/s electrical data to 4 parallel channels of optical signals, each supporting 106.25 Gbit/s data transmission. Reversely, it can convert 4-channel 106.25 Gbit/s optical signals to 8-channel electrical output data on the receiver side. It has been designed to meet the harshest external operating conditions including temperature, humidity and EMI interference. The module offers very high functionality and feature integration, accessible via a two-wire serial interface.

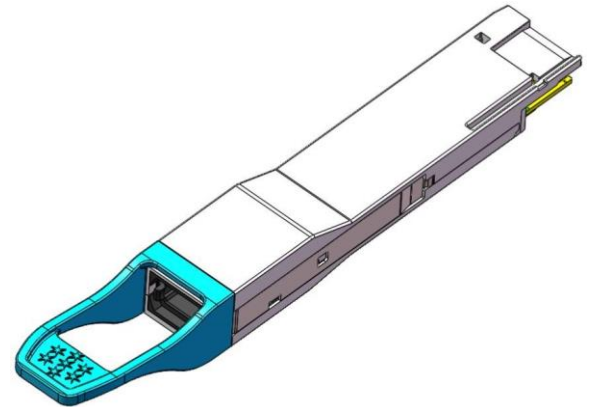

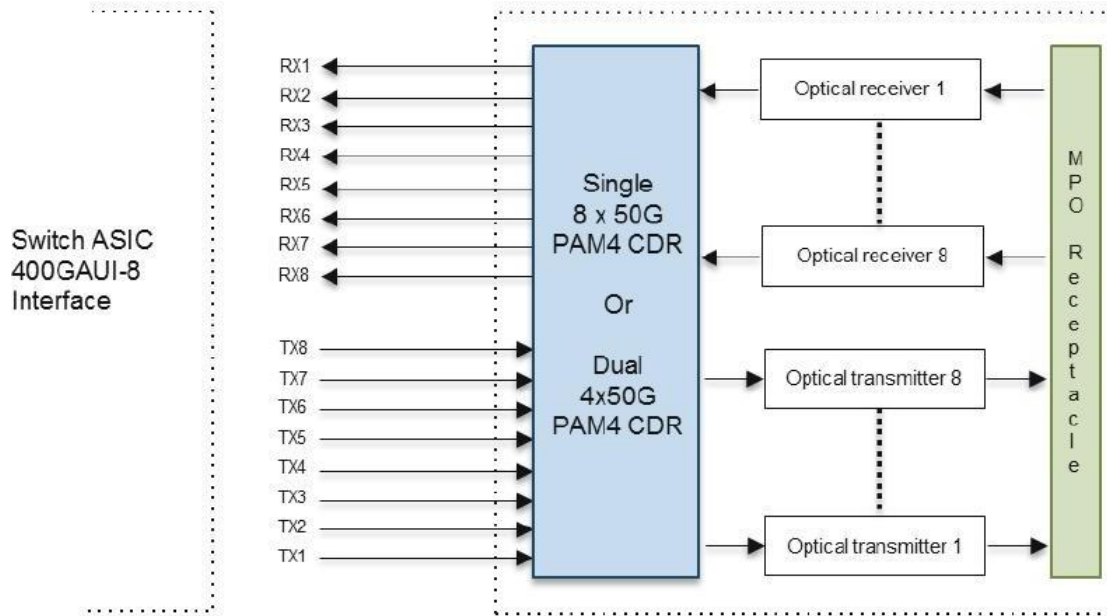

**Figure1. Module Block Diagram**

## Absolute Maximum Ratings

Parameter	Symbol	Min	Max	Unit
Supply Voltage	Vcc	-0.3	3.6	V
Input Voltage	Vin	-0.3	Vcc+0.3	V
Storage Temperature	Tst	-20	85	°C
Case Operating Temperature	Top	0	70	°C
Humidity(non-condensing)	Rh	5	95	%

## Recommended Operating Conditions

Parameter	Symbol	Min	Typical	Max	Unit
Supply Voltage	Vcc	3.13	3.3	3.47	V
Operating Case temperature	Tca	0		70	°C
Data Rate Per Lane	fd		106.25		GBd
Humidity	Rh	5		85	%
Power Dissipation	Pm			10	W

## Electrical Specifications

Parameter	Symbol	Min	Typical	Max	Unit
Differential input impedance	Zin	90	100	110	ohm
Differential Output impedance	Zout	90	100	110	ohm
Differential input voltage	$\Delta V_{in}$			900	mVp-p
Differential output voltage	$\Delta V_{out}$			900	mVp-p
Skew	Sw			300	ps
Bit Error Rate	BER			2.4E-4	-
Near-end Eye Width at 10 <sup>-6</sup> probability(EW6)		0.265			UI
Near-end Eye Height at 10 <sup>-6</sup> probability(EH6)		70			mV
Far-end Eye Width at 10 <sup>-6</sup> probability(EW6)		0.20			UI
Far-end Eye Height at 10 <sup>-6</sup> probability(EH6)		30			mV
Near-end Eye Linearity		0.85			-

### Note:

- BER=2.4E-4; PRBS31Q@26.5625GBd. Pre-FEC
- Differential input voltage amplitude is measured between TxnP and TxnN. Differential output voltage amplitude is measured between RxnP and RxnN

## Optical Characteristics

**Table 3 - Optical Characteristics**

Parameter	Symbol	Min	Typical	Max	Unit	Notes
<b>Transmitter</b>						
Centre Wavelength	$\lambda_c$	130 4.5		131 7.5	nm	-
RMS spectral width	$\Delta\lambda$	30	-	--	nm	-
Average launch power, each lane	P <sub>out</sub>	-2.9	-	4.0	dBm	-
Optical Modulation Amplitude (OMA <sub>outer</sub> ), each lane	OMA	-0.8	-	4.2	dBm	-
Transmitter and dispersion eye closure(TDEC),each lane	TDEC			3.4	dB	
Extinction Ratio	ER	3.5	-	-	dB	-
Average launch power of OFF transmitter, each lane				-15	dB	-
<b>Receiver</b>						
Centre Wavelength	$\lambda_c$	130 4.5		131 7.5	nm	-
Receiver Sensitivity in OMA <sub>outer</sub>	RX <sub>sen</sub>			-4.4	dBm	1
Average power at receiver , each lane input, each lane	P <sub>in</sub>	-5.9		4	dBm	-
Receiver Reflectance				-26	dB	-
LOS Assert		-15			dBm	-
LOS De-Assert – OMA				-8.4	dBm	-
LOS Hysteresis		0.5			dB	-

**Note:**

1. Measured with conformance test signal at TP3 for BER = 2.4E-4 Pre-FEC

## Pin Description

**Table 1- Pad Function Definition**

Pad	Logic	Symbol	Description	Plug Sequence <sup>4</sup>	Notes
1		GND	Ground	1B	1
2	CML-I	Tx2n	Transmitter Inverted Data Input	3B	
3	CML-I	Tx2p	Transmitter Non-Inverted Data Input	3B	
4		GND	Ground	1B	1
5	CML-I	Tx4n	Transmitter Inverted Data Input	3B	
6	CML-I	Tx4p	Transmitter Non-Inverted Data Input	3B	
7		GND	Ground	1B	1
8	LVTTL-I	ModSelL	Module Select	3B	
9	LVTTL-I	ResetL	Module Reset	3B	
10		VccRx	+3.3V Power Supply Receiver	2B	2
11	LVCNOS-I/O	SCL	2-wire serial interface clock	3B	
12	LVCNOS-I/O	SDA	2-wire serial interface data	3B	
13		GND	Ground	1B	1
14	CML-O	Rx3p	Receiver Non-Inverted Data Output	3B	
15	CML-O	Rx3n	Receiver Inverted Data Output	3B	
16		GND	Ground	1B	1
17	CML-O	Rx1p	Receiver Non-Inverted Data Output	3B	
18	CML-O	Rx1n	Receiver Inverted Data Output	3B	
19		GND	Ground	1B	1
20		GND	Ground	1B	1
21	CML-O	Rx2n	Receiver Inverted Data Output	3B	
22	CML-O	Rx2p	Receiver Non-Inverted Data Output	3B	
23		GND	Ground	1B	1
24	CML-O	Rx4n	Receiver Inverted Data Output	3B	
25	CML-O	Rx4p	Receiver Non-Inverted Data Output	3B	
26		GND	Ground	1B	1
27	LVTTL-O	ModPrsL	Module Present	3B	
28	LVTTL-O	IntL	Interrupt	3B	
29		VccTx	+3.3V Power supply transmitter	2B	2
30		Vcc1	+3.3V Power supply	2B	2
31	LVTTL-I	InitMode	Initialization mode; In legacy QSFP applications, the InitMode pad is called LPMODE	3B	
32		GND	Ground	1B	1
33	CML-I	Tx3p	Transmitter Non-Inverted Data Input	3B	
34	CML-I	Tx3n	Transmitter Inverted Data Input	3B	
35		GND	Ground	1B	1
36	CML-I	Tx1p	Transmitter Non-Inverted Data Input	3B	
37	CML-I	Tx1n	Transmitter Inverted Data Input	3B	
38		GND	Ground	1B	1

Pad	Logic	Symbol	Description	Plug Sequence <sup>4</sup>	Notes
39		GND	Ground	1A	1
40	CML-I	Tx6n	Transmitter Inverted Data Input	3A	
41	CML-I	Tx6p	Transmitter Non-Inverted Data Input	3A	
42		GND	Ground	1A	1
43	CML-I	Tx8n	Transmitter Inverted Data Input	3A	
44	CML-I	Tx8p	Transmitter Non-Inverted Data Input	3A	
45		GND	Ground	1A	1
46		Reserved	For future use	3A	3
47		VS1	Module Vendor Specific 1	3A	3
48		VccRx1	3.3V Power Supply	2A	2
49		VS2	Module Vendor Specific 2	3A	3
50		VS3	Module Vendor Specific 3	3A	3
51		GND	Ground	1A	1
52	CML-O	Rx7p	Receiver Non-Inverted Data Output	3A	
53	CML-O	Rx7n	Receiver Inverted Data Output	3A	
54		GND	Ground	1A	1
55	CML-O	Rx5p	Receiver Non-Inverted Data Output	3A	
56	CML-O	Rx5n	Receiver Inverted Data Output	3A	
57		GND	Ground	1A	1
58		GND	Ground	1A	1
59	CML-O	Rx6n	Receiver Inverted Data Output	3A	
60	CML-O	Rx6p	Receiver Non-Inverted Data Output	3A	
61		GND	Ground	1A	1
62	CML-O	Rx8n	Receiver Inverted Data Output	3A	
63	CML-O	Rx8p	Receiver Non-Inverted Data Output	3A	
64		GND	Ground	1A	1
65		NC	No Connect	3A	3
66		Reserved	For future use	3A	3
67		VccTx1	3.3V Power Supply	2A	2
68		Vcc2	3.3V Power Supply	2A	2
69		Reserved	For Future Use	3A	3
70		GND	Ground	1A	1
71	CML-I	Tx7p	Transmitter Non-Inverted Data Input	3A	
72	CML-I	Tx7n	Transmitter Inverted Data Input	3A	
73		GND	Ground	1A	1
74	CML-I	Tx5p	Transmitter Non-Inverted Data Input	3A	
75	CML-I	Tx5n	Transmitter Inverted Data Input	3A	
76		GND	Ground	1A	1
<p>Note 1: QSFP-DD uses common ground (GND) for all signals and supply (power). All are common within the QSFP-DD module and all module voltages are referenced to this potential unless otherwise noted. Connect these directly to the host board signal-common ground plane.</p>					
<p>Note 2: VccRx, VccRx1, Vcc1, Vcc2, VccTx and VccTx1 shall be applied concurrently. Requirements defined for the host side of the Host Card Edge Connector are listed in Table 4. VccRx, VccRx1, Vcc1, Vcc2, VccTx and VccTx1 may be internally connected within the module in any combination. The connector Vcc pins are each rated for a maximum current of 1000 mA.</p>					
<p>Note 3: All Vendor Specific, Reserved and No Connect pins may be terminated with 50 ohms to ground on the host. Pad 65 (No Connect) shall be left unconnected within the module. Vendor specific and Reserved pads shall have an impedance to GND that is greater than 10 kOhms and less than 100 pF.</p>					
<p>Note 4: Plug Sequence specifies the mating sequence of the host connector and module. The sequence is 1A, 2A, 3A, 1B, 2B, 3B. (see Figure 2 for pad locations) Contact sequence A will make, then break contact with additional QSFP-DD pads. Sequence 1A, 1B will then occur simultaneously, followed by 2A, 2B, followed by 3A, 3B.</p>					

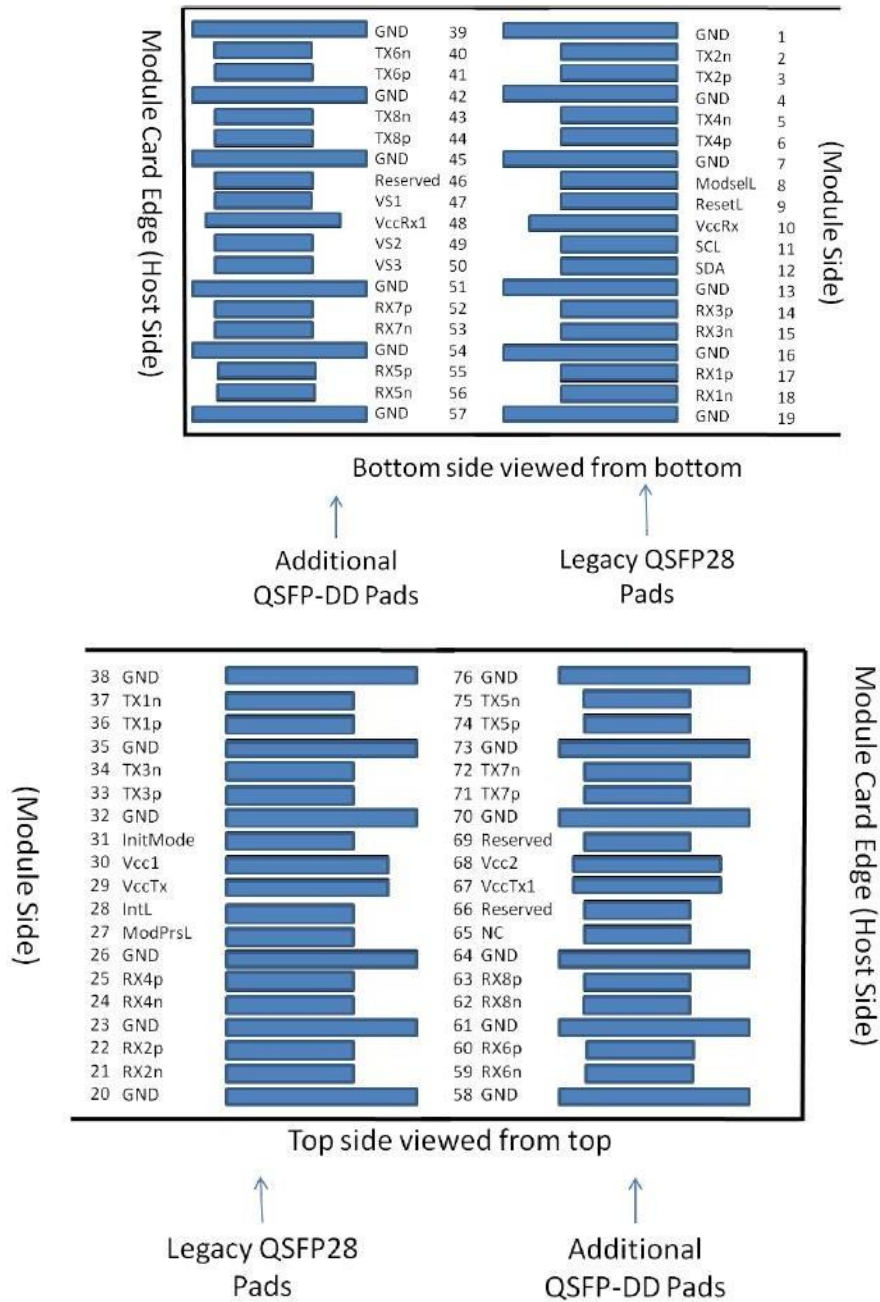

**Figure2. Electrical Pin-out Details**

### ModSel Pin

The ModSel is an input signal that must be pulled to Vcc in the QSFP-DD module. When held low by the host, the module responds to 2-wire serial communication commands. The ModSel allows the use of multiple QSFP-DD modules on a single 2-wire interface bus. When ModSel is “High”, the module shall not respond to or acknowledge any 2-wire interface communication from the host. In order to avoid conflicts, the host system shall not attempt 2-wire interface communications within the ModSel de-assert time after any QSFP-DD modules are deselected. Similarly, the host must wait at least for the period of the ModSel assert time before communicating with the newly selected module. The assertion and de-asserting periods of different modules may overlap as long as the above timing requirements are met.

### ResetL Pin

The ResetL signal shall be pulled to Vcc in the module. A low level on the ResetL signal for longer than the minimum pulse length ( $t_{Reset\_init}$ ) (See Table 13) initiates a complete module reset, returning all user module settings to their default state.

### InitMode Pin

InitMode is an input signal. The InitMode signal must be pulled up to Vcc in the QSFP-DD module. The InitMode signal allows the host to define whether the QSFP-DD module will initialize under host software control (InitMode asserted High) or module hardware control (InitMode deasserted Low). Under host software control, the module shall remain in Low Power Mode until software enables the transition to High Power Mode, as defined in Section 7.5. Under hardware control (InitMode de-asserted Low), the module may immediately transition to High Power Mode after the management interface is initialized. The host shall not change the state of this signal while the module is present. In legacy QSFP applications, this signal is named LPMMode. See SFF-8679 for signal description.

### **ModPrsL Pin**

ModPrsL must be pulled up to Vcc Host on the host board and grounded in the module. The ModPrsL is asserted "Low" when the module is inserted and deasserted "High" when the module is physically absent from the host connector.

### **IntL Pin**

IntL is an output signal. The IntL signal is an open collector output and must be pulled to Vcc Host on the host board. When the IntL signal is asserted Low it indicates a change in module state, a possible module operational fault or a status critical to the host system. The host identifies the source of the interrupt using the 2-wire serial interface. The IntL signal is deasserted "High" after all set interrupt flags are read.



## Power Supply Filtering

The host board should use the power supply filtering shown in Figure3.

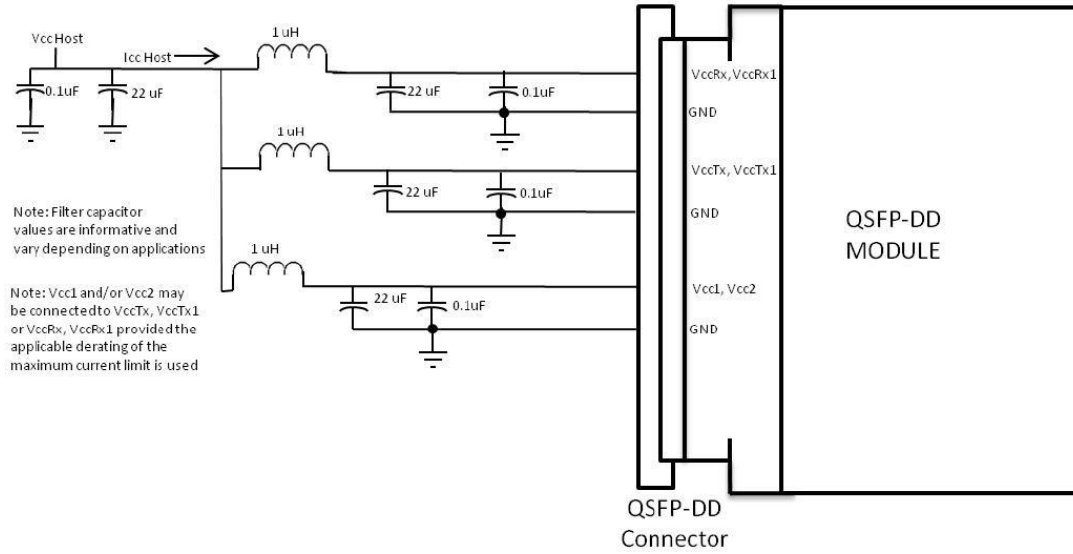

**Figure3. Host Board Power Supply Filtering**

## DIAGNOSTIC MONITORING INTERFACE

Digital diagnostics monitoring function is available on all QSFP DD products. A 2-wire serial interface provides user to contact with module.

### Memory Structure and Mapping

This limits the management memory that can be directly accessed by the host to 256 bytes, which is divided in Lower Memory (addresses 00h through 7Fh) and Upper Memory (addresses 80h through FFh).

A larger addressable management memory is required for all but the most basic modules. This is supported by a structure of 128-byte pages, together with a mechanism for dynamically mapping any of the 128-byte pages from a larger internal management memory space into Upper Memory the host addressable space.

The addressing structure of the additional internal management memory<sup>2</sup> is shown in Figure 4 The management memory inside the module is arranged as a unique and always host accessible address space of 128 bytes (Lower Memory) and as multiple upper address subspaces of 128 bytes each (Pages), only one of which is selected as host visible in Upper Memory. A second level of Page selection is possible for Pages for which several instances exist (e.g. where a bank of pages with the same Page number exists).

This structure supports a flat 256 byte memory for passive copper modules and permits timely access to addresses in the Lower Memory, e.g. Flags and Monitors. Less time critical entries, e.g. serial ID information and threshold settings, are available with the Page Select function in the Lower Page. For more complex modules which require a larger amount of management memory the host needs to use dynamic mapping of the various Pages into the host addressable Upper Memory address space, whenever needed.

**Note:** The management memory map has been designed largely after the QSFP memory map. This memory map has been changed in order to accommodate 8 electrical lanes and to limit the required memory space. The single address approach is used as found in QSFP. Paging is used in order to enable time critical interactions between host and module.

### Supported Pages

A basic 256 byte subset of the Management Memory Map is mandatory for all CMIS compliant devices. Other parts are only available for paged memory modules, or when advertised by the module. See CMIS V4.0 for details regarding the advertisement of supported management memory spaces.

In particular, support of the Lower Memory and of Page 00h is required for all modules, including passive copper cables. These pages are therefore always implemented. Additional support for Pages 01h, 02h and bank 0 of Pages 10h and 11h is required for all paged memory modules.

Bank 0 of pages 10h-1Fh, provides lane-specific registers for the first 8 lanes, and each additional bank provides support for additional 8 lanes. Note, however, that the allocation of information over the banks may be page specific and may not to be related to grouping data for 8 lanes.

The structure allows address space expansion for certain types of modules by allocating additional Pages. Moreover, additional banks of pages

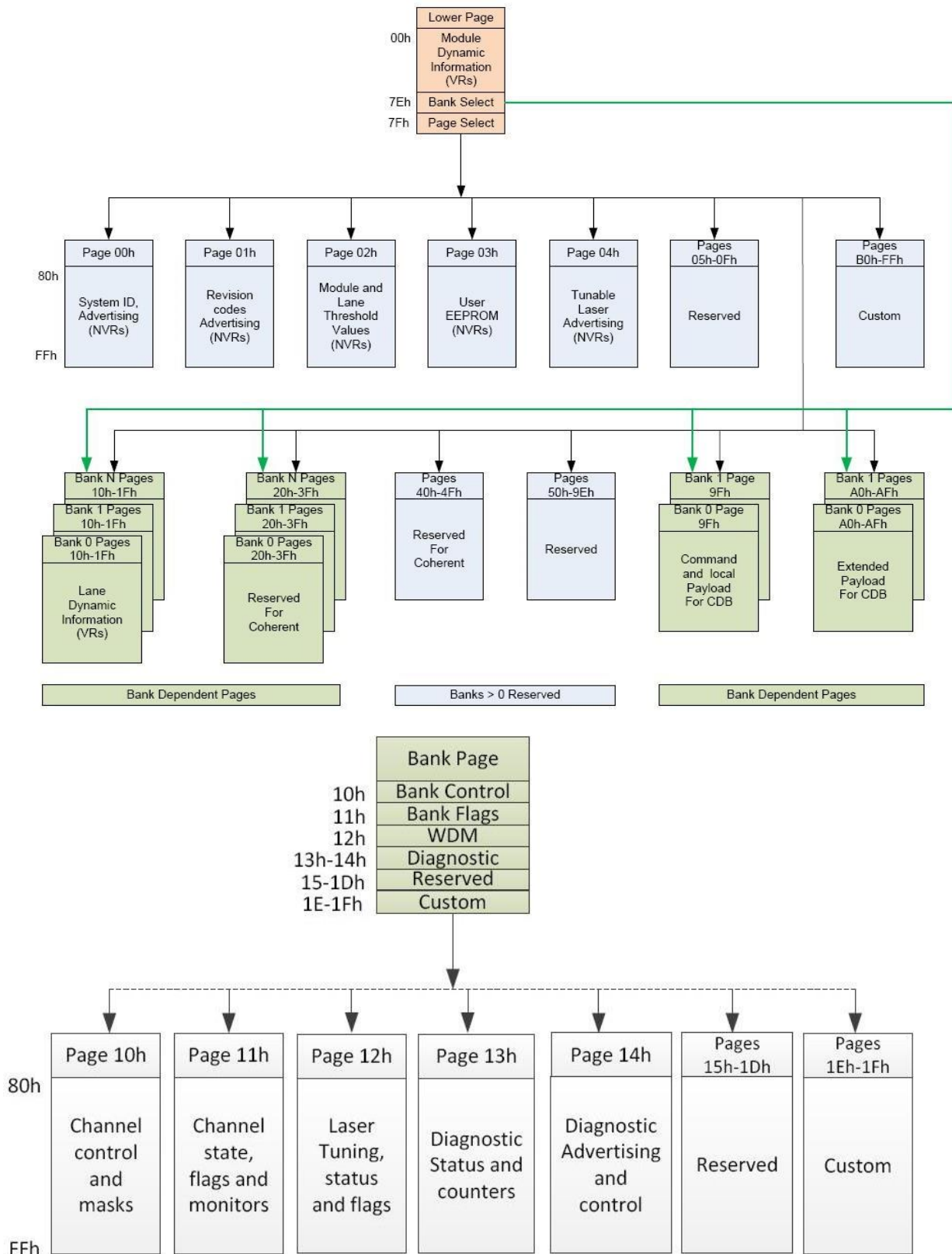

**Figure4. QSFP DD Memory Map**

## Mechanical Dimensions

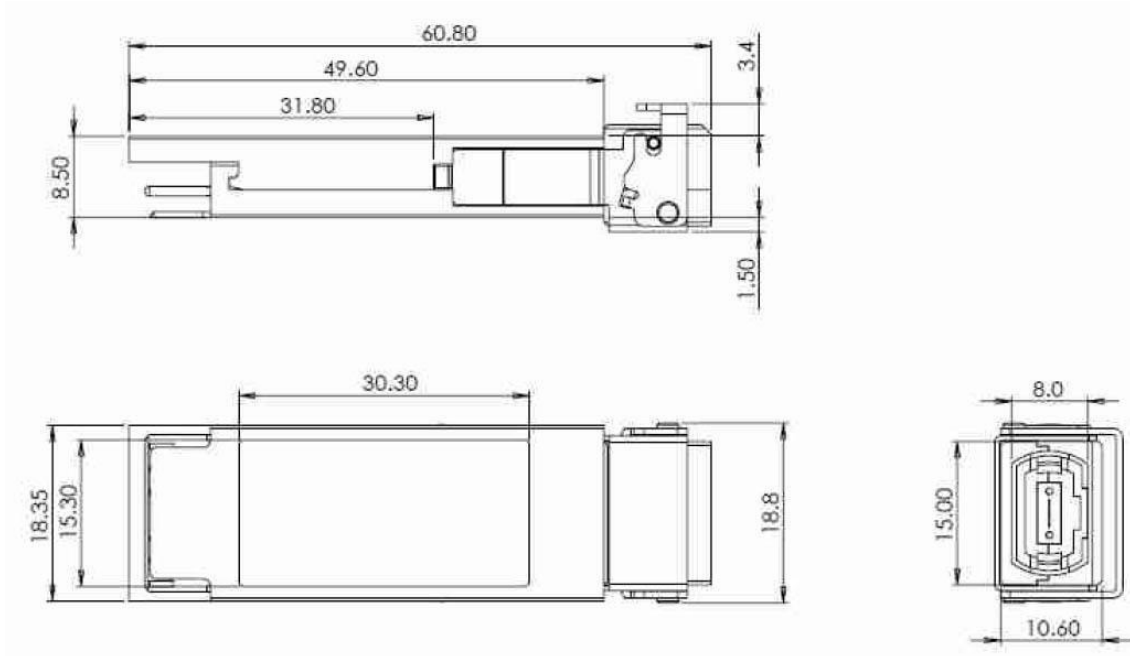

**Figure6. Mechanical Specifications**

## Regulatory Compliance

Gigaligh GQD-MDO401-SR8C(B/C) transceivers are Class 1 Laser Products. They are compliant with the following standards:

Feature	Standard
Laser Safety	IEC 60825-1:2014 (3 <sup>rd</sup> Edition) IEC 60825-2:2004/AMD2:2010 EN 60825-1-2014 EN 60825-2:2004+A1+A2
Electrical Safety	EN 62368-1: 2014 IEC 62368-1:2014 UL 62368-1:2014
Environmental protection	Directive 2011/65/EU with amendment(EU)2015/863
CE EMC	EN55032: 2015 EN55035: 2017 EN61000-3-2:2014 EN61000-3-3:2013
FCC	FCC Part 15, Subpart B ANSI C63.4-2014

## References

1. QSFP DD MAS Rev4.0
2. CMIS V4.0
3. IEEE802.3cd 200GBASE-SR4
4. OIF CEI-56G-VSR-PAM4

## Ordering information

Part Number	Product Description
NQS-S400-L005	QSFP DD, 400GBASE-DR4, 500m on Single mode Fiber (SMF), with DSP Power consumption <10W, MPO-12 connector.