

NQP-MDO101-XXXX**Features**

4 independent full-duplex channels

Up to 28Gb/s data rate per channel

QSFP28 and SFP28 MSA compliant

Up to 100m OM4 MMF transmission

Operating case temperature: 0 to 70°C

Single 3.3V power supply

Maximum power consumption of 3.5W for QSFP28 terminal and 1.0W for each SFP28 terminal

RoHS compliant

**Applications**

100G Ethernet

Infiniband EDR

Description

This product is a high data rate parallel active optical cable (AOC), to overcome the bandwidth limitation of traditional copper cable. The AOC is terminated with a QSFP28 module at one end and four SFP28 modules at the other. With the QSFP28 terminal, it offers 4 independent data transmission channels and 4 data receiving channels via multimode ribbon fibers, each capable of 25Gb/s operation. The fiber ribbon then fans out to four fiber cables, each of which is terminated with an SFP28 module. Consequently, an aggregate data rate of 100Gb/s over up to 100m transmission can be achieved by this product, to support the ultra-fast computing data exchange.

The product is designed with form factor, optical/electrical connection according to the QSFP28 and SFP28 Multi-Source Agreements (MSA). It has been designed to meet the harshest external operating conditions including temperature, humidity and EMI interference.

Functional Description

The QSFP28 module converts the parallel electrical input signals into parallel optical signals by a driven Vertical Cavity Surface Emitting Laser (VCSEL) array inside the QSFP28 module on its transmitter side. The optical signals propagate first through 4 optical data transmission lanes in the multimode ribbon fibers and then through those of the 4 separate dual-core fiber cables. They are then captured by the photo diodes inside the receivers of the 4 SFP28 modules at the other end. The optical signals are converted into electrical signals, which are outputted by the receivers of the 4 SFP28 modules individually.

In the reverse direction, each of the 4 SFP28 modules converts the electrical input signal into an optical signal by a driven VCSEL inside the module on its transmitter side. The 4 optical signals propagate first through the other transmission lanes of the 4 separate dual-core fiber cables and then through those in the multimode ribbon fibers. They are captured by the photo diode array inside the QSFP28 on its receiver side. The optical signals are converted into parallel electrical signals and outputted. Consequently, the QSFP28 terminal of the cable has 8 ports, 4 for data transmission and 4 for data receiving, to provide a total of 100Gb/s data exchange rate while each of the 4 SFP28 terminals at the other end has 2 ports, 1 for data transmission and 1 for receiving, to provide 25Gb/s data exchange rate.

QSFP28 Terminal

A single +3.3V power supply is required to power up this product. Both power supply pins VccTx and VccRx are internally connected and should be applied concurrently. As per MSA specifications the module offers 7 low speed hardware control pins (including the 2-wire serial interface): ModSelL, SCL, SDA, ResetL, LPMODE, ModPrsL and IntL.

Module Select (ModSelL) is an input pin. When held low by the host, this product responds to 2-wire serial communication commands. The ModSelL allows the use of this product on a single 2-wire interface bus – individual ModSelL lines must be used.

Serial Clock (SCL) and Serial Data (SDA) are required for the 2-wire serial bus communication interface and enable the host to access the QSFP28 memory map.

The ResetL pin enables a complete reset, returning the settings to their default state, when a low level on the ResetL pin is held for longer than the minimum pulse length. During the execution of a reset the host shall disregard all status bits until it indicates a completion of the reset interrupt. The product indicates this by posting an IntL (Interrupt) signal with the Data_Not_Ready bit negated in the memory map. Note that on power up (including hot insertion) the module should post this completion of reset interrupt without requiring a reset.

Low Power Mode (LPMODE) pin is used to set the maximum power consumption for the product in order to protect hosts that are not capable of cooling higher power modules, should such modules be accidentally inserted.

Module Present (ModPrsL) is a signal local to the host board which, in the absence of a product, is normally pulled up to the host Vcc. When the product is inserted into the connector, it completes the path to ground through a resistor on the host board and asserts the signal. ModPrsL then indicates it is present by setting ModPrsL to a “Low” state.

Interrupt (IntL) is an output pin. “Low” indicates a possible operational fault or a status critical to the host system. The host identifies the source of the interrupt using the 2-wire serial interface. The IntL pin is an open collector output and must be pulled to the Host Vcc voltage on the Host board.

SFP28 Terminals

The SFP28 module electrical interface is compliant to SFI electrical specifications. The transmitter input and receiver output impedance is 100 Ohms differential. Data lines are internally AC coupled. The module provides differential termination and reduce differential to common mode conversion for quality signal termination and low EMI. SFI typically operates over 200 mm of improved FR4 material or up to about 150mm of standard FR4 with one connector.

The transmitter converts 25Gbit/s serial PECL or CML electrical data into serial optical data. An open collector compatible Transmit Disable (Tx_Dis) is provided. Logic “1” or no connection on this pin will disable the laser from transmitting. Logic “0” on this pin provides normal operation. The transmitter has an internal automatic power control loop (APC) to ensure constant optical power output across supply voltage and temperature variations. An open collector compatible Transmit Fault (Tx_Fault) is provided. TX_Fault is module output contact that when high, indicates that the module transmitter has detected a fault condition related to laser operation or safety. The TX_Fault output contact is an open drain/collector and shall be pulled up to the Vcc_Host in the host with a resistor in the range 4.7-10 kΩ. TX_Disable is a module input contact. When TX_Disable is asserted high or left open, the SFP28 module transmitter output shall be turned off. This contact shall be pulled up to VccT with a 4.7 kΩ to 10 kΩ resistor.

The receiver converts 25Gbit/s serial optical data into serial PECL/CML electrical data. An open collector compatible Loss of Signal is provided. Rx_LOS when high indicates an optical signal level below that specified in the relevant standard. The Rx_LOS contact is an open drain/collector output and shall be pulled up to Vcc_Host in the host with a resistor in the range 4.7-10 kΩ, or with an active termination. Power supply filtering is recommended for both the

transmitter and receiver. The Rx_LOS signal is intended as a preliminary indication to the system in which the SFP28 is installed that the received signal strength is below the specified range. Such an indication typically points to non-installed cables, broken cables, or a disabled, failing or a powered off transmitter at the far end of the cable.

Pin Assignments and Definitions

QSFP28Terminal

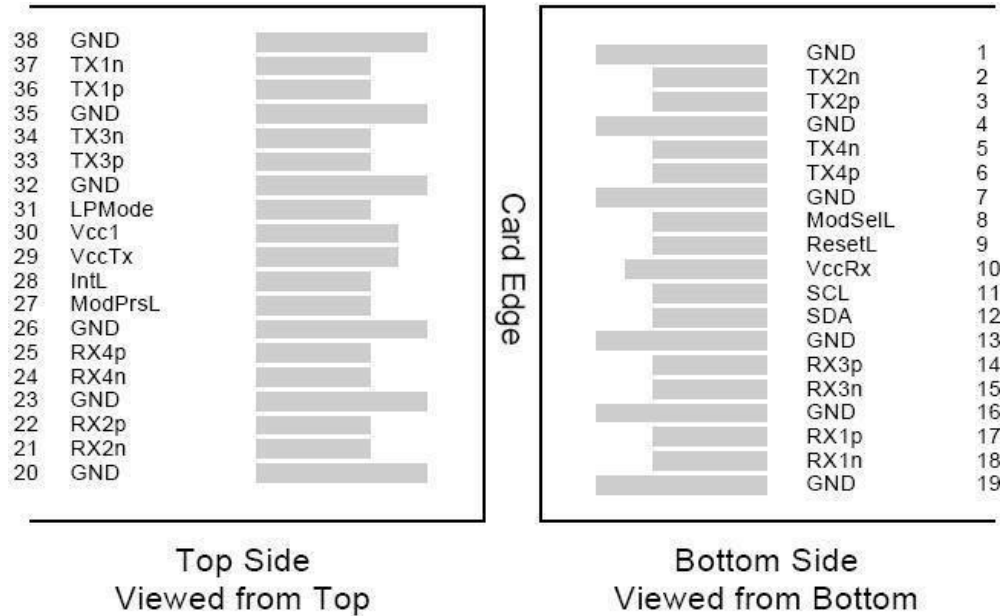

Figure 1. MSA compliant QSFP28 Connector

Pin Definition

PI N	Logic	Symbol	Name/Description	Notes
1		GND	Ground	1
2	CML-I	Tx2n	Transmitter Inverted Data Input	
3	CML-I	Tx2p	Transmitter Non-Inverted Data output	
4		GND	Ground	1
5	CML-I	Tx4n	Transmitter Inverted Data Input	
6	CML-I	Tx4p	Transmitter Non-Inverted Data output	
7		GND	Ground	1
8	LVTLL-I	ModSelL	Module Select	
9	LVTLL-I	ResetL	Module Reset	
10		VccRx	+3.3V Power Supply Receiver	2
11	LVC MOS-I/O	SCL	2-Wire Serial Interface Clock	
12	LVC MOS-I/O	SDA	2-Wire Serial Interface Data	
13		GND	Ground	
14	CML-O	Rx3p	Receiver Non-Inverted Data Output	
15	CML-O	Rx3n	Receiver Inverted Data Output	
16		GND	Ground	1
17	CML-O	Rx1p	Receiver Non-Inverted Data Output	
18	CML-O	Rx1n	Receiver Inverted Data Output	
19		GND	Ground	1
20		GND	Ground	1
21	CML-O	Rx2n	Receiver Inverted Data Output	
22	CML-O	Rx2p	Receiver Non-Inverted Data Output	
23		GND	Ground	1
24	CML-O	Rx4n	Receiver Inverted Data Output	1
25	CML-O	Rx4p	Receiver Non-Inverted Data Output	
26		GND	Ground	1
27	LVTTL-O	ModPrsL	Module Present	
28	LVTTL-O	IntL	Interrupt	
29		VccTx	+3.3 V Power Supply transmitter	2
30		Vcc1	+3.3 V Power Supply	2
31	LVTTL-I	LPMode	Low Power Mode	
32		GND	Ground	1
33	CML-I	Tx3p	Transmitter Non-Inverted Data Input	
34	CML-I	Tx3n	Transmitter Inverted Data Output	
35		GND	Ground	1
36	CML-I	Tx1p	Transmitter Non-Inverted Data Input	
37	CML-I	Tx1n	Transmitter Inverted Data Output	
38		GND	Ground	1

Notes:

1. GND is the symbol for signal and supply (power) common for QSFP28 modules. All are common within the QSFP28 module and all module voltages are referenced to this potential unless otherwise noted. Connect these directly to the host board signal common ground plane.
2. VccRx, VccI and VccTx are the receiving and transmission power suppliers and shall be applied concurrently. Recommended host board power supply filtering is shown in Figure 4 below. Vcc Rx, VccI and VccTx may be internally connected within the QSFP28 transceiver module in any combination. The connector pins are each rated for a maximum current of 1000mA.

SFP28Terminals

The SFP28 modules are hot-pluggable. Hot pluggable refers to plugging in or unplugging a module while the host board is powered. The SFP28 host connector is a 0.8 mm pitch 20 position right angle improved connector specified by SFF-8083, or stacked connector with equivalent with equivalent electrical performance. Host PCB contact assignment is shown in Figure 2 and contact definitions are given in the PINdescription table. SFP28 module contacts mates with the host in the order of ground, power, followed by signal as illustrated by Figure 3 and the contact sequence order listed in the PIN description table.

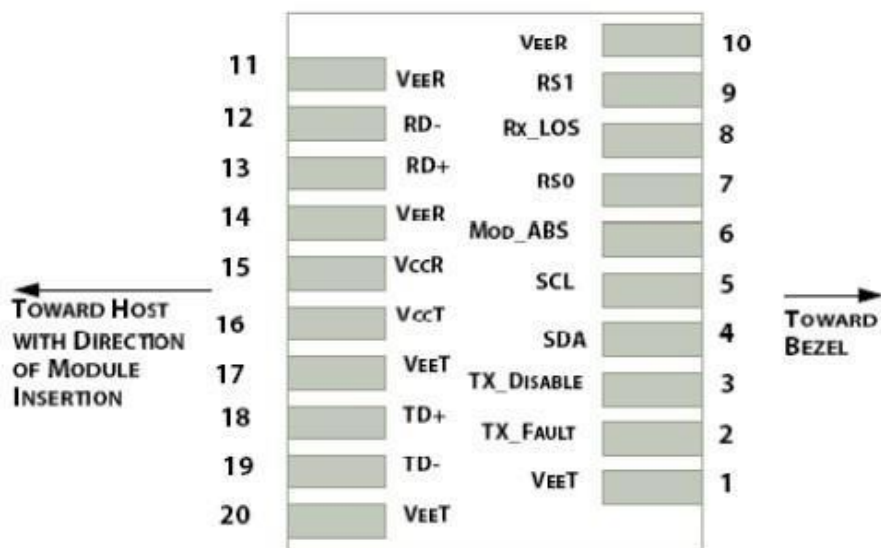

Figure 2. SFP28 Module Interface to Host



Figure 3. SFP28 Module Contact Assignment

Pin definition

PIN	Logic	Symbol	Name / Description	Notes
1		VeeT	Module Transmitter Ground	1
2	LVTTL-O	TX_Fault	Module Transmitter Fault	
3	LVTTL-I	TX_Dis	Transmitter Disable; Turns off transmitter laser output	
4	LVTTL-I/O	SDA	2-Wire Serial Interface Data Line	2
5	LVTTL-I	SCL	2-Wire Serial Interface Clock	2
6		MOD_DEF0	Module Definition, Grounded in the module	
7	LVTTL-I	RS0	Receiver Rate Select	
8	LVTTL-O	RX_LOS	Receiver Loss of Signal Indication Active LOW	
9	LVTTL-I	RS1	Transmitter Rate Select (not used)	
10		VeeR	Module Receiver Ground	1
11		VeeR	Module Receiver Ground	1
12	CML-O	RD-	Receiver Inverted Data Output	
13	CML-O	RD+	Receiver Data Output	
14		VeeR	Module Receiver Ground	1
15		VccR	Module Receiver 3.3 V Supply	
16		VccT	Module Receiver 3.3 V Supply	
17		VeeT	Module Transmitter Ground	1
18	CML-I	TD+	Transmitter Non-Inverted Data Input	
19	CML-I	TD-	Transmitter Inverted Data Input	
20		VeeT	Module Transmitter Ground	1

Notes:

1. Module ground pins GND are isolated from the module case.
2. Shall be pulled up with 4.7K-10Kohms to a voltage between 3.15V and 3.45V on the hostboard.

Recommended Power Supply Filters

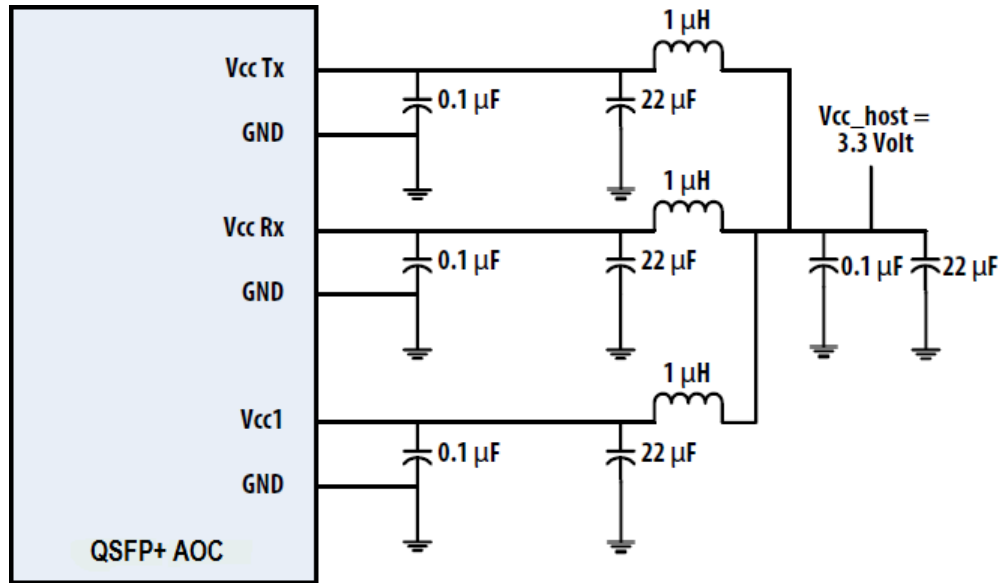

Figure 4. Recommended Power Supply Filter for QSF28 Terminal

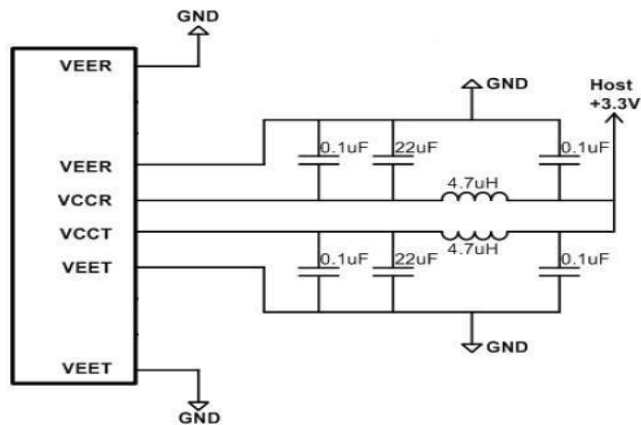

Figure 5. Recommended Power Supply Filter for SFP28 Terminals

Absolute Maximum Ratings

Parameter	Symbol	Min	Max	Units	Notes
Storage Temperature	T _S	-40	85	°C	
Operating Case Temperature	T _{OP}	0	70	°C	
Power Supply Voltage	V _{CC}	0	3.6	V	
Relative Humidity (non-condensation)	RH	0	85	%	

Recommended Operating Conditions and Power Supply Requirements

Parameter	Symbol	Min	Typical	Max	Units
Operating Case Temperature	T _{OP}	0		70	°C
Power Supply Voltage	V _{CC}	3.135	3.3	3.465	V
Data Rate, each Lane (QSFP28)			25.78125	28.05	Gb/s
Data Rate (each SFP28)			25.78125	28.05	Gb/s
Control Input Voltage High		2		V _{CC}	V
Control Input Voltage Low		0		0.8	V

Electrical Characteristics

The following electrical characteristics are defined over the Recommended Operating temperature and supply voltage unless otherwise specified.

(QSFP28 Terminal)

Parameter	Symbol	Min	Typical	Max	Units	Notes
Power Consumption, each Terminal				3.5	W	
Supply Current, each Terminal	I _{CC}			1060	mA	
Transceiver Power-on Initialization Time				2000	ms	1
Transmitter (each Lane)						
Single Ended Input Voltage Tolerance (Note 2)		0		3.6	V	
AC Common Mode Input Voltage Tolerance		15			mV	RMS
Differential Input Voltage Swing Threshold		50			mV _{pp}	LOSA Threshold
Differential Input Voltage Swing	V _{in,pp}	180		1000	mV _{pp}	
Differential Input Impedance	Z _{in}	90	100	110	Ohm	

Total Jitter				0.40	UI	
Deterministic Jitter				0.15	UI	
Receiver (each Lane)						
Single Ended Output Voltage		0		3.6	V	
AC Common Mode Output Voltage				7.5	mV	RMS
Differential Output Voltage Swing	Vout,pp	300		1000	mVpp	
Differential Output Impedance	Zout	90	100	110	Ohm	
Total Jitter				0.3	UI	
Deterministic Jitter				0.15	UI	

(SFP28 Terminals)

Parameter	Symbol	Min	Typical	Max	Units	Notes
Power Consumption				1000	mW	
Supply Current, each SFP28	Icc			300	mA	
Transceiver Power-on Initialization Time				300	ms	
Transmitter						
Single Ended Input Voltage Tolerance		0		3.6	V	
AC Common Mode Voltage Tolerance		15			mV	RMS
Differential Input Voltage Swing	Vin,pp	180		700	mV	
Differential Input Impedance	Zin	90	100	110	Ohm	
Data Dependent Input Jitter	DDJ			0.40	UI	
Data Input Total Jitter	TJ			0.15	UI	
Receiver						
Single Ended Output Voltage		0		3.6	V	
AC Common Mode Voltage				7.5	mV	RMS
Differential Output Voltage Swing	Vout,pp	300		850	mV	
Differential Output Impedance	Zout	90	100	110	Ohm	
Rx Output Rise and Fall Time	Tr/Tf	30			ps	20% to 80%
Total Jitter	TJ			0.3	UI	
Deterministic Jitter	DJ			0.15	UI	

MechanicalDimensions

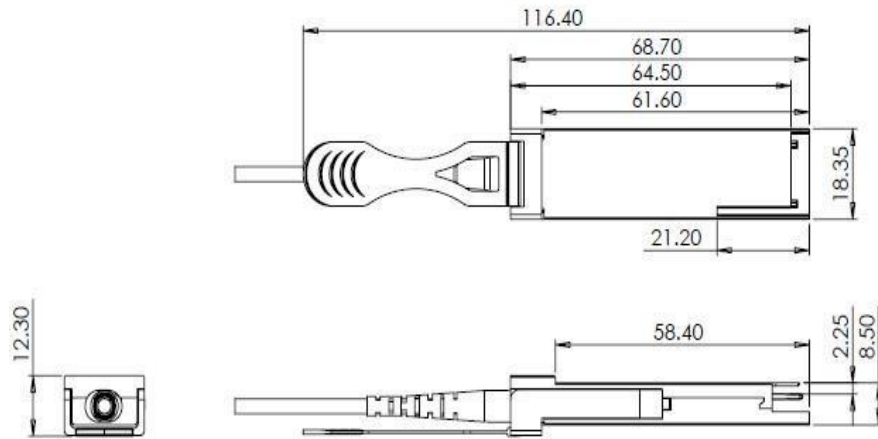

Figure 6. Mechanical Outline of QSFP28 Terminal

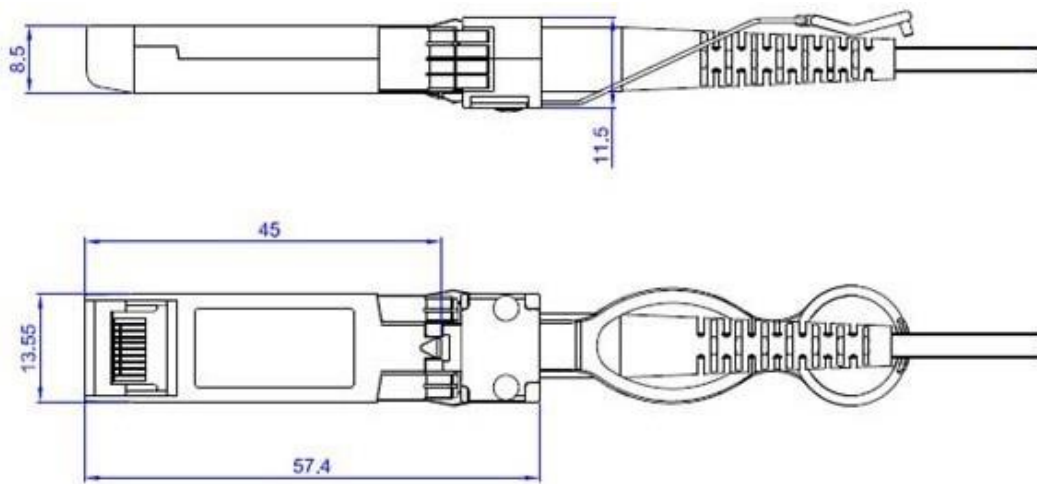
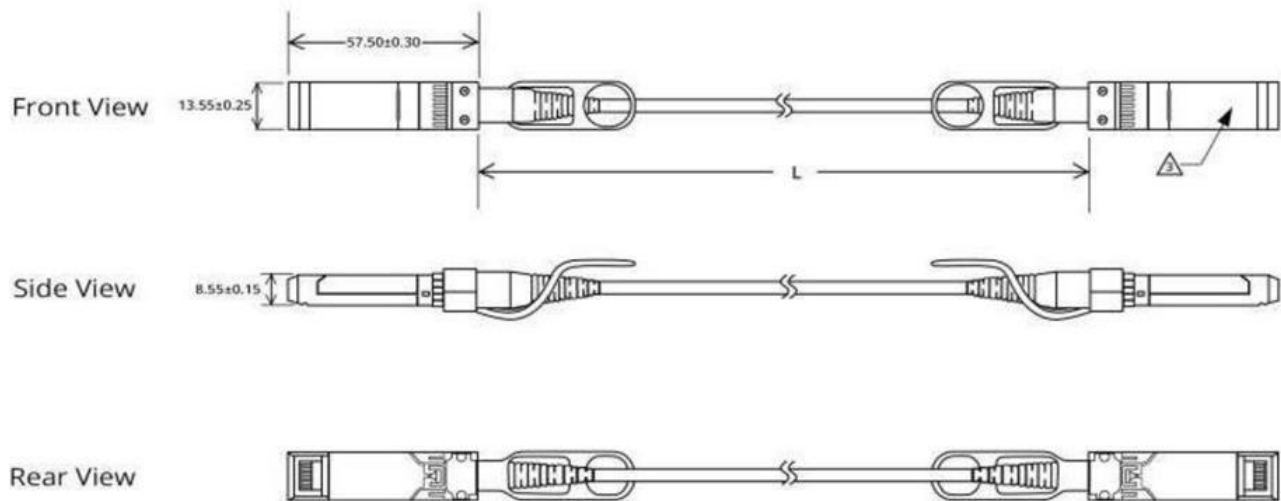

Figure 7. Mechanical Outline of SFP28 Terminal

The length

The length starts at the module connection and the module connection (as shown below). Acceptable Standards are shown below



Acceptable standard

Type	Length (m)	tolerance (cm)
AOC	$L \leq 1$	$+7 \sim -0$
	$1 < L < 7$	$+10 \sim -0$
	$L \geq 7$	$+2\% \sim -0$

Lable solt size

type	Size (mm)	tolerance (mm)
lable	31mm*10mm	± 0.5 mm

Order Information:

NQP-MDO101-XXXX	QSFP28 to 4x SFP28 breakout active optical cable with full real-time digitaldiagnostic monitoring
-----------------	---

where "x" denotes cable length in meters. Examples of cable length offered are as follows: x = 1 for 1m x = 50

for 50m

x = 5 for 5m x = 75 for 75m

x = 10 for 10m x = 100 for 100m

ESD

This transceiver is specified as ESD threshold 1kV for SFI pin and 2kV for all others electrical input pins, tested per MIL-STD-883, Method 3015.4 /JESD22-A114-A (HBM). However, normal ESD precautions are still required during the handling of this module. This transceiver is shipped in ESD protective packaging. It should be removed from the packaging and handled only in an ESD protected environment.