

NQS-S100-L20

Features:

Hot pluggable QSFP28 MSA form factor
 Lane data rate of 25.78125Gb/s,27.953Gb/s
 Up to 20km reach for G.652 SMF
 Single +3.3V power supply
 Operating case temperature: 0 °C ~70 °C
 Transmitter: cooled 4x28Gb/s LAN WDMDFB TOSA
 Receiver: 4x28Gb/s PIN ROSA
 4x28G Electrical Serial Interface(CEI-28G-VSR)
 Maximum power consumption3.5W
 Duplex LC receptacle
 RoHS compliant

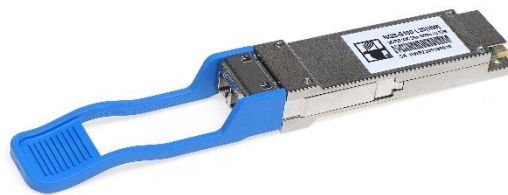

Applications:

100GBASE-LR4 Ethernet Links
 OTN OTU4 4I1-9D1F

Part Number Ordering Information

NQS-S100-L20	QSFP28 LR4 20km optical transceiver with full real-time digital diagnostic monitoring and pull tab
--------------	--

1. General Description

This product is a 100Gb/s transceiver module designed for optical communication applications compliant to 100GBASE-LR4 of the IEEE P802.3ba and OTU4 4I1-9D1F standard. The module converts 4 input channels of 25Gb/s electrical data to 4 channels of LAN WDM optical signals and then multiplexes them into a single channel for 100Gb/s optical transmission. Reversely on the receiver side, the module de-multiplexes a 100Gb/s optical input into 4 channels of LAN WDM optical signals and then converts them to 4 output channels of electrical data.

The central wavelengths of the 4 LAN WDM channels are 1295.56, 1300.05, 1304.58 and 1309.14 nm, members of the LAN WDM wavelength grid defined in IEEE 802.3ba. The high-performance cooled LAN WDM DFB transmitters and high sensitivity PIN receivers provide superior performance for 100Gigabit Ethernet applications up to 20km links and compliant to optical interface with IEEE802.3ba Clause 88 100GBASE-LR4 requirements.

The product is designed with form factor, optical/electrical connection and digital diagnostic interface according to the QSFP+ Multi-Source Agreement (MSA). It has been designed to meet the harshest external operating conditions including temperature, humidity and EMI interference.

2. Functional Description

The transceiver module receives 4 channels of 25Gb/s electrical data, which are processed by a 4-channel Clock and Data Recovery (CDR) IC that reshapes and reduces the jitter of each electrical signal. Subsequently, each of 4 DML laser driver IC's converts one of the 4 channels of electrical signals to an optical signal that is transmitted from one of the 4 cooled DML lasers which are packaged in the Transmitter Optical Sub-Assembly (TOSA). Each laser launches the optical signal in specific wavelength specified in IEEE802.3ba 100GBASE-LR4 requirements. These 4-lane optical signals will be optically multiplexed into a single fiber by a 4-to-1 optical WDM MUX. The optical output power of each channel is maintained constant

by an automatic power control (APC) circuit. The transmitter output can be turned off by TX_DIS hardware signal and/or 2-wire serial interface.

The receiver receives 4-lane LAN WDM optical signals. The optical signals are de-multiplexed by a 1-to-4 optical DEMUX and each of the resulting 4 channels of optical signals is fed into one of the 4 receivers that are packaged into the Receiver Optical Sub-Assembly (ROSA). Each receiver converts the optical signal to an electrical signal. The regenerated electrical signals are retimed and de-jittered and amplified by the RX portion of the 4-channel CDR. The retimed 4-lane output electrical signals are compliant with IEEE CAUI-4 interface requirements. In addition, each received optical signal is monitored by the DOM section. The monitored value is reported through the 2-wire serial interface. If one or more received optical signal is weaker than the threshold level, RX_LOS hardware alarm will be triggered.

A single +3.3V power supply is required to power up this product. Both power supply pins VccTx and VccRx are internally connected and should be applied concurrently. As per MSA specifications the module offers 7 low speed hardware control pins (including the 2-wire serial interface): ModSelL, SCL, SDA, ResetL, LPMODE, ModPrsL and IntL.

Module Select (ModSelL) is an input pin. When held low by the host, this product responds to 2-wire serial communication commands. The ModSelL allows the use of this product on a single 2-wire interface bus – individual ModSelL lines must be used.

Serial Clock (SCL) and Serial Data (SDA) are required for the 2-wire serial bus communication interface and enable the host to access the QSFP28 memory map.

The ResetL pin enables a complete reset, returning the settings to their default state, when a low level on the ResetL pin is held for longer than the minimum pulse length. During the execution of a reset the host shall disregard all status bits until it indicates a completion of the reset interrupt. The product indicates this by posting an IntL (Interrupt) signal with the Data_Not_Ready bit negated in the memory map. Note that on power up (including hot insertion) the module should post this completion of reset interrupt without requiring a reset.

Low Power Mode (LPMODE) pin is used as TX disable. If the LPMODE pin is in the high state, the modulator will tune off the Laser.

Module Present (Mod PrsL) is a signal local to the host board which, in the absence of a product, is normally pulled up to the host Vcc. When the product is inserted into the connector, it completes the path to ground through a resistor on the host board and asserts the signal. ModPrsL then indicates its present by setting ModPrsL to a “Low” state.

Interrupt (IntL) pin is used as RX-LOS. When “Low”, it indicates a RX-LOS assert. Other alarm asserting does not go through IntL pin.

3. Transceiver Block Diagram

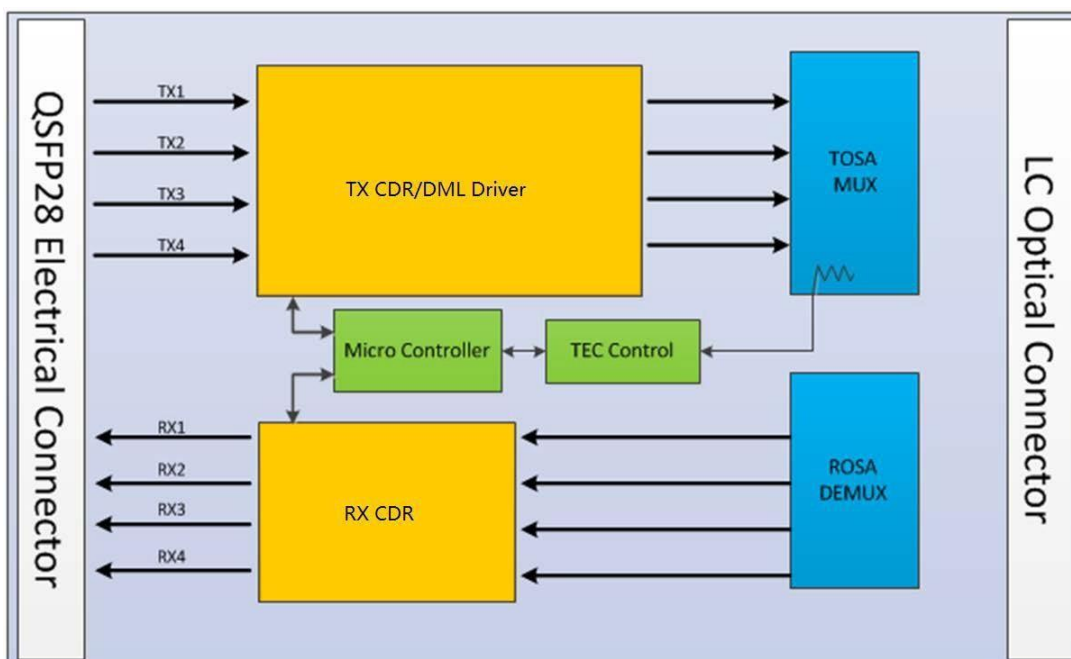
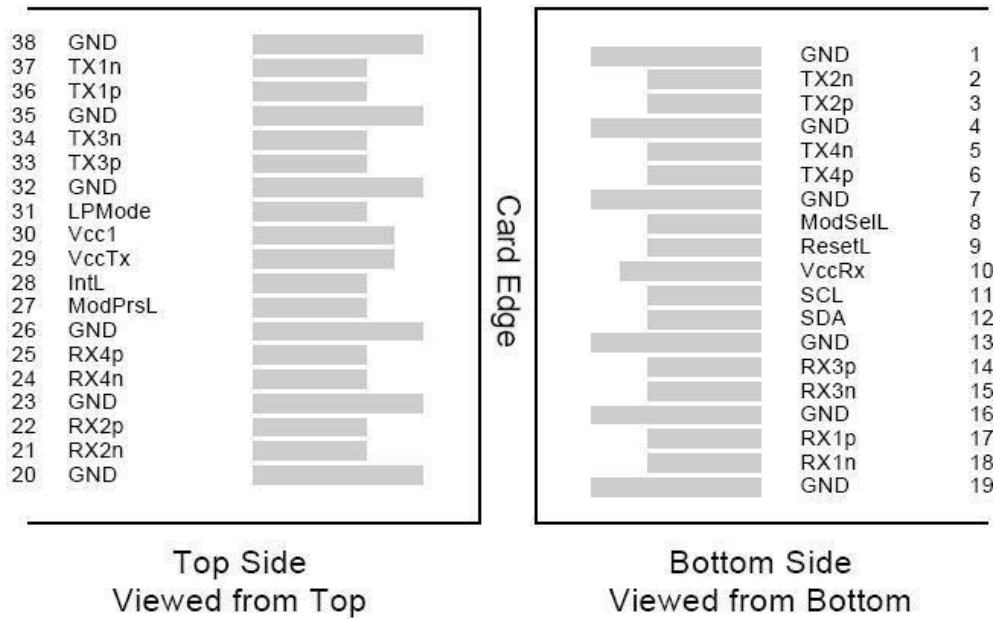

Figure 1. Transceiver Block Diagram

4. Pin Assignment and Description

Figure 2. MSA Compliant Connector



5. Pin Definition

PIN	Logic	Symbol	Name/Description	Notes
1		GND	Ground	1
2	CML-I	Tx2n	Transmitter Inverted Data Input	
3	CML-I	Tx2p	Transmitter Non-Inverted Data output	
4		GND	Ground	1
5	CML-I	Tx4n	Transmitter Inverted Data Input	
6	CML-I	Tx4p	Transmitter Non-Inverted Data output	
7		GND	Ground	1
8	LVTLL-I	ModSelL	Module Select	
9	LVTLL-I	ResetL	Module Reset	
10		VccRx	+3.3V Power Supply Receiver	2
11	LVC MOS-I/O	SCL	2-Wire Serial Interface Clock	
12	LVC MOS-I/O	SDA	2-Wire Serial Interface Data	
13		GND	Ground	
14	CML-O	Rx3p	Receiver Non-Inverted Data Output	
15	CML-O	Rx3n	Receiver Inverted Data Output	
16		GND	Ground	1
17	CML-O	Rx1p	Receiver Non-Inverted Data Output	
18	CML-O	Rx1n	Receiver Inverted Data Output	
19		GND	Ground	1
20		GND	Ground	1
21	CML-O	Rx2n	Receiver Inverted Data Output	
22	CML-O	Rx2p	Receiver Non-Inverted Data Output	
23		GND	Ground	1
24	CML-O	Rx4n	Receiver Inverted Data Output	1
25	CML-O	Rx4p	Receiver Non-Inverted Data Output	

26		GND	Ground	1
27	LVTTL-O	ModPrsL	Module Present	
28	LVTTL-O	IntL	Interrupt	
29		VccTx	+3.3 V Power Supply transmitter	2
30		Vcc1	+3.3 V Power Supply	2
31	LVTTL-I	LPMode	Low Power Mode	
32		GND	Ground	1
33	CML-I	Tx3p	Transmitter Non-Inverted Data Input	
34	CML-I	Tx3n	Transmitter Inverted Data Output	
35		GND	Ground	1
36	CML-I	Tx1p	Transmitter Non-Inverted Data Input	
37	CML-I	Tx1n	Transmitter Inverted Data Output	
38		GND	Ground	1

Notes:

1. GND is the symbol for signal and supply (power) common for QSFP28 modules. All are common within the QSFP28 module and all module voltages are referenced to this potential unless otherwise noted. Connect these directly to the host board signal common ground plane.
2. VccRx, Vcc1 and VccTx are the receiver and transmitter power suppliers and shall be applied concurrently. Recommended host board power supply filtering is shown in Figure 4 below. Vcc Rx, Vcc1 and Vcc Tx may be internally connected within the QSFP28 transceiver module in any combination. The connector pins are each rated for a maximum current of 1000mA.

6. Recommended Power Supply Filter

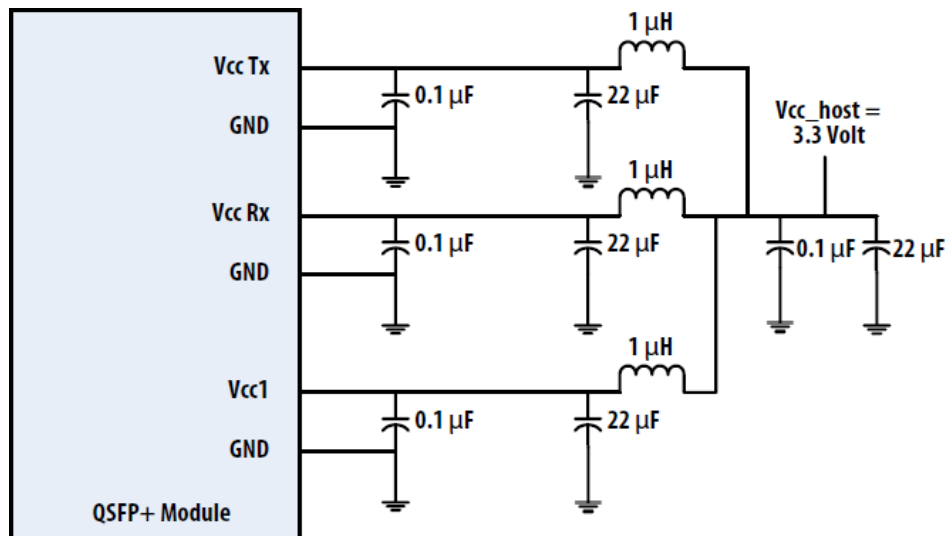

Figure 3. Recommended Power Supply Filter

7. Absolute Maximum Ratings

It has to be noted that the operation in excess of any individual absolute maximum ratings might cause permanent damage to this module.

Parameter	Symbol	Min	Max	Units	Note
Storage Temperature	T_S	-40	85	°C	
Operating Case Temperature	T_{OP}	0	70	°C	
Power Supply Voltage	V_{CC}	-0.5	3.6	V	
Relative Humidity (non-condensation)	RH	0	85	%	
Damage Threshold, each Lane	TH_d	5.5		dBm	

8. Recommended Operating Conditions and Power Supply Requirements

Parameter	Symbol	Min	Typical	Max	Units
Operating Case Temperature	T_{OP}	0		70	°C
Power Supply Voltage	V_{CC}	3.135	3.3	3.465	V
Data Rate, each Lane		25.78		27.95	Gb/s
Control Input Voltage High		2		V_{CC}	V
Control Input Voltage Low		0		0.8	V
Link Distance with G.652	D	0.002		10	km

9. Electrical Characteristics

The following electrical characteristics are defined over the Recommended Operating Environment unless otherwise specified.

Parameter	Symbol	Min	Typical	Max	Units	Notes
Power Consumption				3.5	W	
Supply Current	I_{CC}			1.12	A	
Transmitter (each Lane)						
Differential Input Voltage Swing	$V_{in,pp}$			900	mVpp	
Differential Input Impedance	Z_{in}	90	100	110	Ohm	
Receiver (each Lane)						
Differential Output Voltage Swing	$V_{out,pp}$	100		400	mVpp	1
		300		600		
		400		800		
		600		1200		
Differential Output Impedance	Z_{out}	90	100	110	Ohm	

Notes:

- Output voltage is settable in 4 discrete ranges via I2C. Default range is 400 – 800 mV.

10. Optical Characteristics

QSFP28 100GBASE-LR4						
Parameter	Symbol	Min	Typical	Max	Unit	Notes
Signaling Speed per Channel			25.7812 5		Gbps	
Lane Wavelength	L0	1294.53	/	1296.59	nm	
	L1	1299.02	/	1301.09	nm	
	L2	1303.54	/	1305.63	nm	
	L3	1308.09	/	1310.19	nm	
Transmitter						
Side Mode Suppression Ratio	SMSR	30			dB	
Total Average Launch Power	P _T			10.5	dBm	
Average Launch Power, each Lane	P _{AVG}	-2.3		4.5	dBm	
OMA, each Lane	P _{OMA}	-1.3		4.5	dBm	
Difference in Launch Power between any Two Lanes (OMA)	P _{Tx,diff}			5	dB	
Launch Power in OMA minus Transmitter and Dispersion Penalty (TDP), each Lane		-2.3			dBm	
TDP, each Lane	TDP			2.2	dB	
Extinction Ratio	ER	4			dB	
RIN _{20OMA}	RIN			-130	dB/Hz	
Optical Return Loss Tolerance	TOL			20	dB	
Transmitter Reflectance	R _T			-12	dB	
Eye Mask {X1, X2, X3, Y1, Y2, Y3}		{0.25, 0.4, 0.45, 0.25, 0.28, 0.4}				1
Average Launch Power OFF Transmitter, each Lane	P _{off}			-30	dBm	
Receiver						
Signaling Speed per Channel			25.7812 5		Gbps	
Lane Wavelength	L0	1294.53	/	1296.59	nm	
	L1	1299.02	/	1301.09	nm	
	L2	1303.54	/	1305.63	nm	
	L3	1308.09	/	1310.19	nm	
Total Average Receive Power				10.5	dBm	
Average Receive Power, each Lane		-10.6		4.5	dBm	
Receive Power (OMA), each Lane				4.5	dBm	
Receiver Sensitivity (OMA), each Lane	SEN			-9.6	dBm	2
Stressed Receiver Sensitivity (OMA), each Lane				-7.8	dBm	
Difference in Receive Power between any Two Lanes (OMA)	P _{Rx,diff}			5.5	dB	
LOS Assert	LOSA	-25			dBm	
LOS De-assert	LOSD			-13	dBm	
LOS Hysteresis	LOSH	0.5		6	dB	

Notes:

1. Compliant to IEEE 802.3ba.
2. Measured with conformance test signal at receiver input for BER = 1x10⁻¹².

QSFP28 OTU4						
Parameter	Symbol	Min	Typical	Max	Unit	Notes
Signaling Speed per Channel			27.95		Gbps	
Lane Wavelength	L0	1294.53	/	1296.59	nm	
	L1	1299.02	/	1301.09	nm	
	L2	1303.54	/	1305.63	nm	
	L3	1308.09	/	1310.19	nm	
Transmitter						
Side Mode Suppression Ratio	SMSR	30			dB	
Total Average Launch Power	P _T			10	dBm	
Average Launch Power, each Lane	P _{AVG}	0		4	dBm	
Channel Power Difference	P _{out,diff}			5	dB	
Extinction Ratio	ER	4		6.5	dB	
Optical Return Loss Tolerance	TOL			20	dB	
Transmitter Reflectance	R _T			-12	dB	
Average Launch Power OFF Transmitter, each Lane	P _{off}			-30	dBm	
Receiver						
Signaling Speed per Channel			27.95		Gbps	
Lane Wavelength	L0	1294.53	/	1296.59	nm	
	L1	1299.02	/	1301.09	nm	
	L2	1303.54	/	1305.63	nm	
	L3	1308.09	/	1310.19	nm	
Total Average Receive Power				10.5	dBm	
Average Receive Power, each Lane		-11.4		4	dBm	
Receiver Sensitivity , each Lane	SEN			-11.4	dBm	1
Total Average Launch Power	PIN			10	dBm	
Difference in Receive Power between any Two Lanes (OMA)	Prx,diff			5.5	dB	
LOS Assert	LOSA	-25			dBm	
LOS De-assert	LOSD			-13	dBm	
LOS Hysteresis	LOSH	0.5		6	dB	

Notes:

- 1、 Specified at a BER of 10⁻⁶ (pre-FEC), per ITU-T G.sup39.

11. Digital Diagnostic Functions

The following digital diagnostic characteristics are defined over the Recommended Operating Environment unless otherwise specified. It is compliant to SFF-8436.

Parameter	Symbol	Min	Max	Units	Notes
Temperature monitor absolute error	DMI_Temp	-3	3	°C	Over operating temperature range
Supply voltage monitor absolute error	DMI_VCC	-3%	+3%	V	Over full operating range
Channel RX power monitor absolute error	DMI_RX_Ch	-2	2	dB	
Channel Bias current monitor	DMI_Ibias_Ch	-10%	10%	mA	Ch1~Ch4
Channel TX power monitor absolute error	DMI_TX_Ch	-2	2	dB	

Mechanical Dimensions

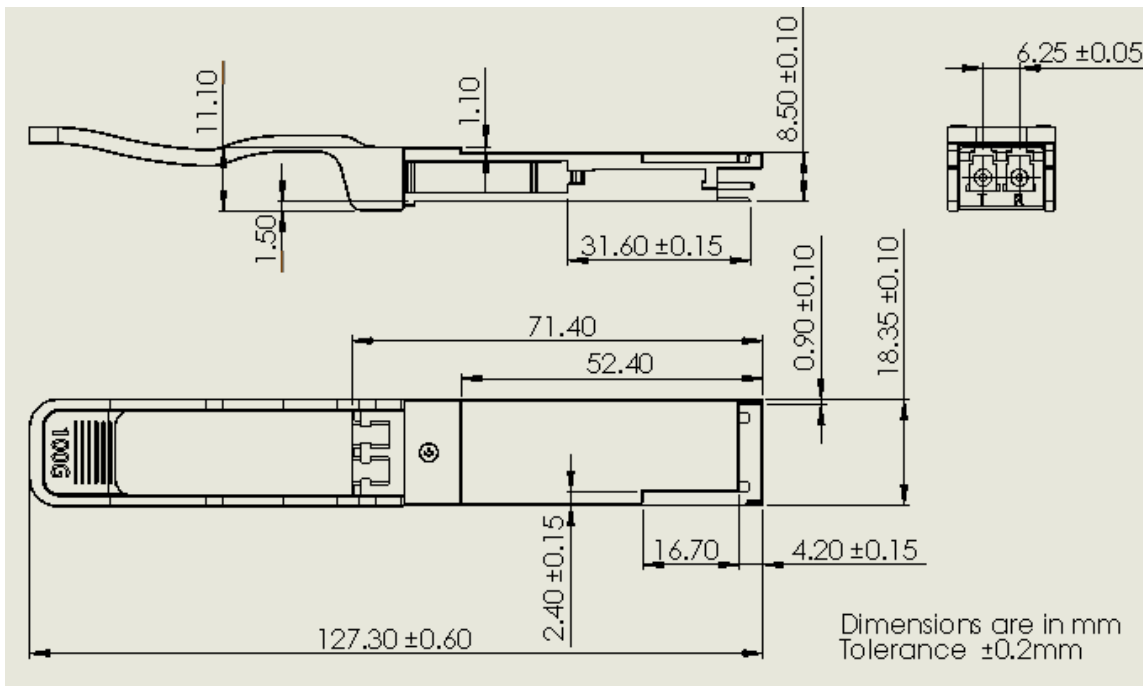

Figure 4.
Mechanical Outline

12. ESD

This transceiver is specified as ESD threshold 1KV for SFI pins and 2KV for all others electrical input pins, tested per MIL-STD-883, Method 3015.4 /JESD22-A114-A (HBM). However, normal ESD precautions are still required during the handling of this module. This transceiver is shipped in ESD protective packaging. It should be removed from the packaging and handled only in an ESD protected environment.

13. Laser Safety

This is a Class 1 Laser Product according to IEC 60825-1:2007. This product complies with 21 CFR 1040.10 and 1040.11 except for deviations pursuant to Laser Notice No. 50, dated (June 24, 2007).