

NPC-xx03-08CD

Features:

18 CWDM Wavelengths Available
Build-in Isolator Optional

Description:

Hot-Pluggable Duplex LC/PC Connector
Single +3.3V Power Supply
Operating Temperature from 0°C to 70°C
Compliant with ITU-T G694.2
Compliant with Telcordia (Bellcore)GR-468-CORE
Designed to meet Laser Class 1 Compliant with IEC60825-1



Applications:

SONET OC-3/SDH STM-1
Fast Ethernet
Other Optical Links

Description:

NPC-xx03-08CD CWDM Transceiver products provide optical networking equipment manufacturers with a timely and cost-effective tool in supporting the unceasing demand for higher bandwidth equipment build-outs in the enterprise access and metropolitan area networks. There are 18 center wavelengths available from 1271nm to 1611nm. The 20nm channel spacing allows for un-cooled laser operation, a high yield manufacturing process, and lower cost Mux/Demux technology, thus providing a complete cost-effective solution for various data and telecom applications.

Specification:
Absolute Maximum Ratings:(T_C=25°C)

Parameter	Symbol	Min.	Max.	Units
Storage Temperature	T _{st}	-40	+85	°C
Case Operating Temperature	T _{op}	0	+70	°C
Supply Voltage	V _{cc}	0	V _{cc}	V
Output Current	I _o	0	30	mA

Operating Environment:

Parameter	Symbol	Min.	Max.	Units
Supply Voltage	V _{CC}	+3.1	+3.5	V
Ambient Operating Temperature	T _A	-20	70	°C

Electrical and Optical Characteristics(Condition: T_c= T_{op})

Parameter	Symbol	Min.	Typical	Max.	Unit
Transmitter Differential Input Voltage	+/-TX_DAT	650		2000	mV p-p
Supply Current	ICC		200	250	mA
Tx_Disable Input Voltage – Low	VIL	0		0.8	V
Tx_Disable Input Voltage – High	VIH	2.0		V _{cc}	V
Tx_Fault Output Voltage – Low	VOL	0		0.8	V
Tx_Fault Output Voltage – High	VOH	2.0		V _{cc}	V
Receiver Differential Output Voltage	+/-RX_DAT	400		2000	mV p-p
Rx_LOS Output Voltage- Low	VOL	0		0.8	V
Rx_LOS Output Voltage- High	VOH	2.0		V _{cc}	V
Transmitter					
Data Rate	B	-	155	-	Mb/s
Output Center Wavelength(0~70°C)	λ _C	λ _{-6.5}	λ	λ _{+6.5}	nm
Output Spectral Width	Δλ	-	-	1	nm
Average Output Power	P _O	-5	-	0	dBm
Extinction Ratio	E.R.	9	-	-	dB
Rise and Fall Time (20~80%)	T _r	-		0.15	ns
Data Input Voltage-High	VIHS	V _{cc} -1.16	-	V _{cc} -0.89	V
Data Input Voltage -Low	VILS	V _{cc} -1.82	-	V _{cc} -1.48	V
Supply Current	ICC	-	-	120	mA
Output Optical Eye	Compliant with Eye Mask Defined in IEEE 802.3 standard				
Receiver					
Date Rate	B	-	155	-	Mb/s
Receive Sensitivity	S	-	-	-34	dBm
Maximum Input Power	P _{max}	0	-	-	dBm
Operating Wavelength	λ _c	1100	-	1620	nm
RX_LOS Assert	LOS A	-45			dBm
RX_LOS De-assert	LOS D			-35	dBm
Hysteresis	-		2.0		dBm
Supply Current	ICC	-	-	110	mA
Rise and Fall Time (20~80%)	T _r /T _f			1.3	ns
Output High Voltage	VOH	V _{cc} -1.03	-	V _{cc} -0.89	V
Output Low Voltage	VOL	V _{cc} -1.82	-	V _{cc} -1.63	V

Timing Characteristics:

Parameter	Symbol	Min.	Typical	Max.	Unit
TX_DISABLE Assert Time	t_off		3	10	Usec
TX_DISABLE Negate Time	t_on		0.5	1	msec
Time to Initialize Include Reset of TX_FAULT	t_int		30	300	msec
TX_FAULT from Fault to Assertion	t_fault		20	100	Usec
TX_DISBEL Time to Start Reset	t_reset	10			Usec
Receiver Loss of Signal Assert Time (off to On)	T _A ,RX_LOS			100	Usec
Receiver Loss of Signal Assert Time (On to Off)	T _d ,RX_LOS			100	Usec

Digital Diagnostic Monitor Characteristics

The following digital diagnostic characteristics are defined over the Recommended Operating Environment unless otherwise specified. It is compliant to SFF8472 Rev10.2 with internal calibration mode. For external calibration mode please contact our sales staff.

Parameter	Symbol	Min.	Max.	Unit
Temperature monitor absolute error	DMI_Temp	-3	3	degC
Laser power monitor absolute error	DMI_TX	-3	3	dB
RX power monitor absolute error	DMI_RX	-3	3	dB
Supply voltage monitor absolute error	DMI_VCC	-0.08	0.08	V
Bias current monitor	DMI_Ibias	-10%	10%	mA

Block Diagram of Transceiver:

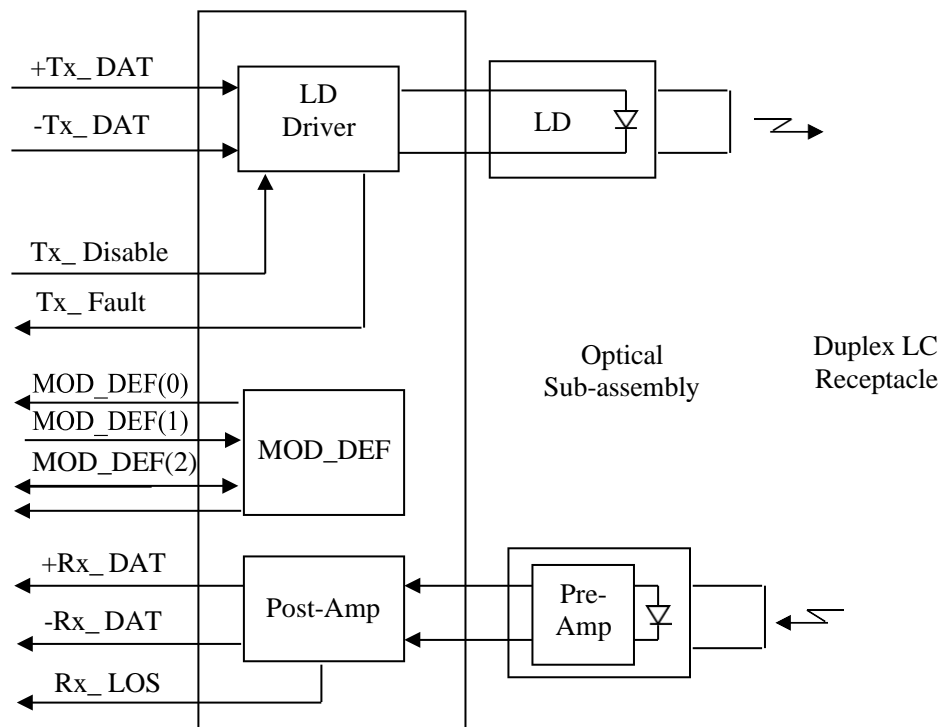

Pin Assignment:

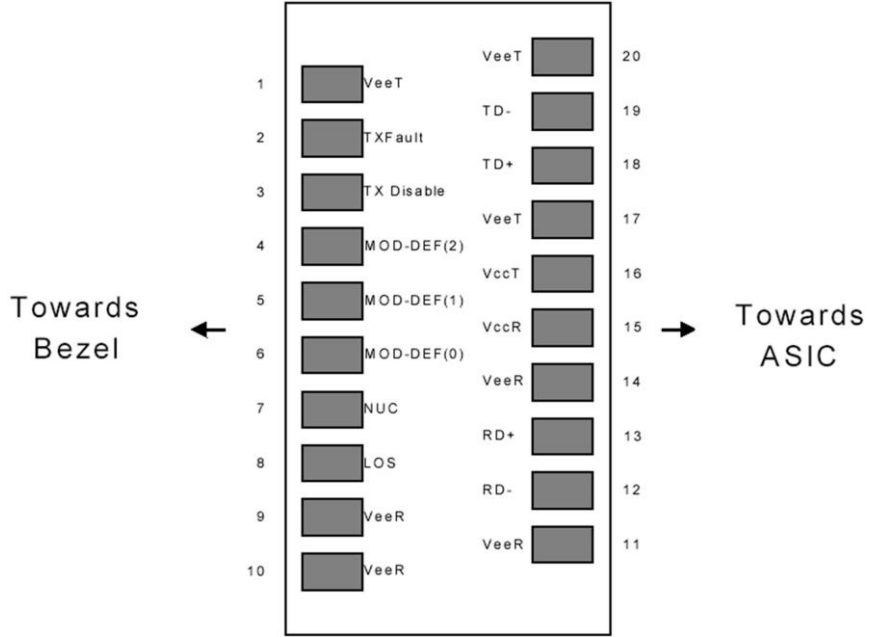

Pin out of Connector Block on Host Board

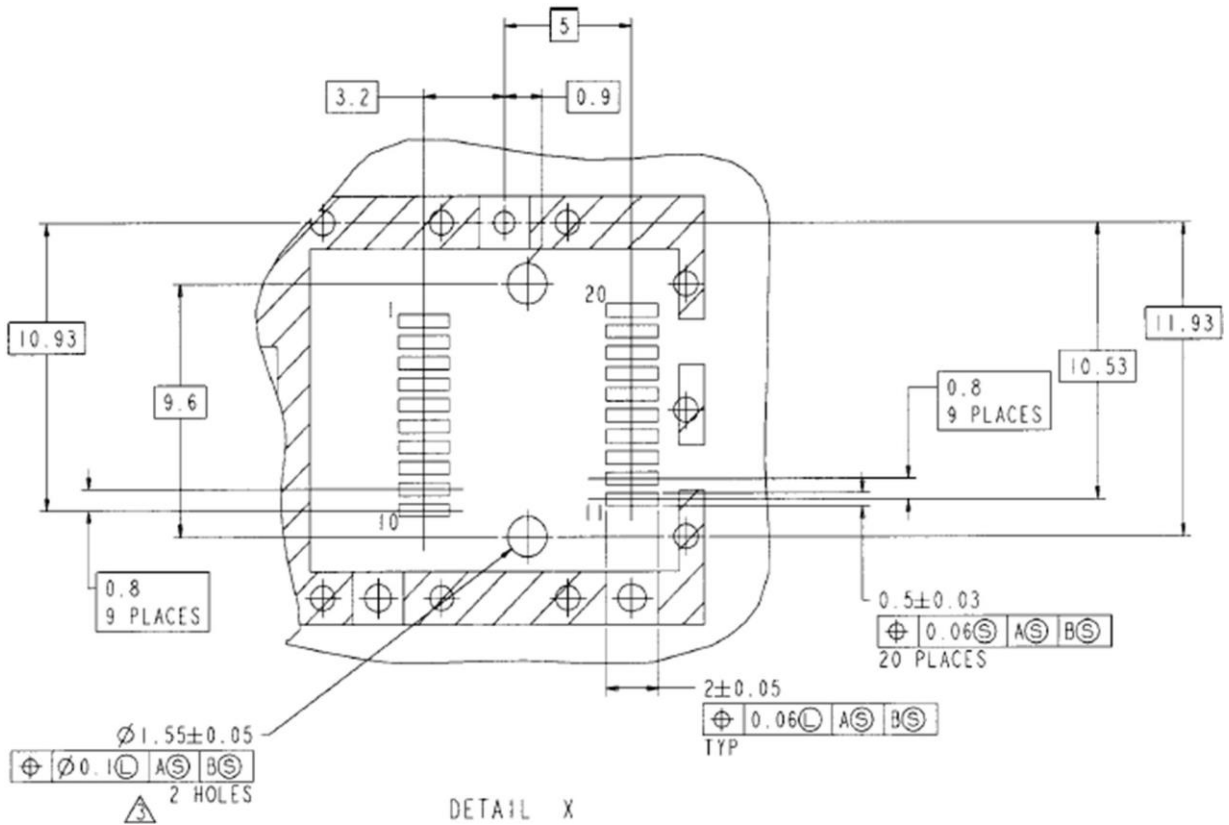

SFP Host Board Mechanical Layout

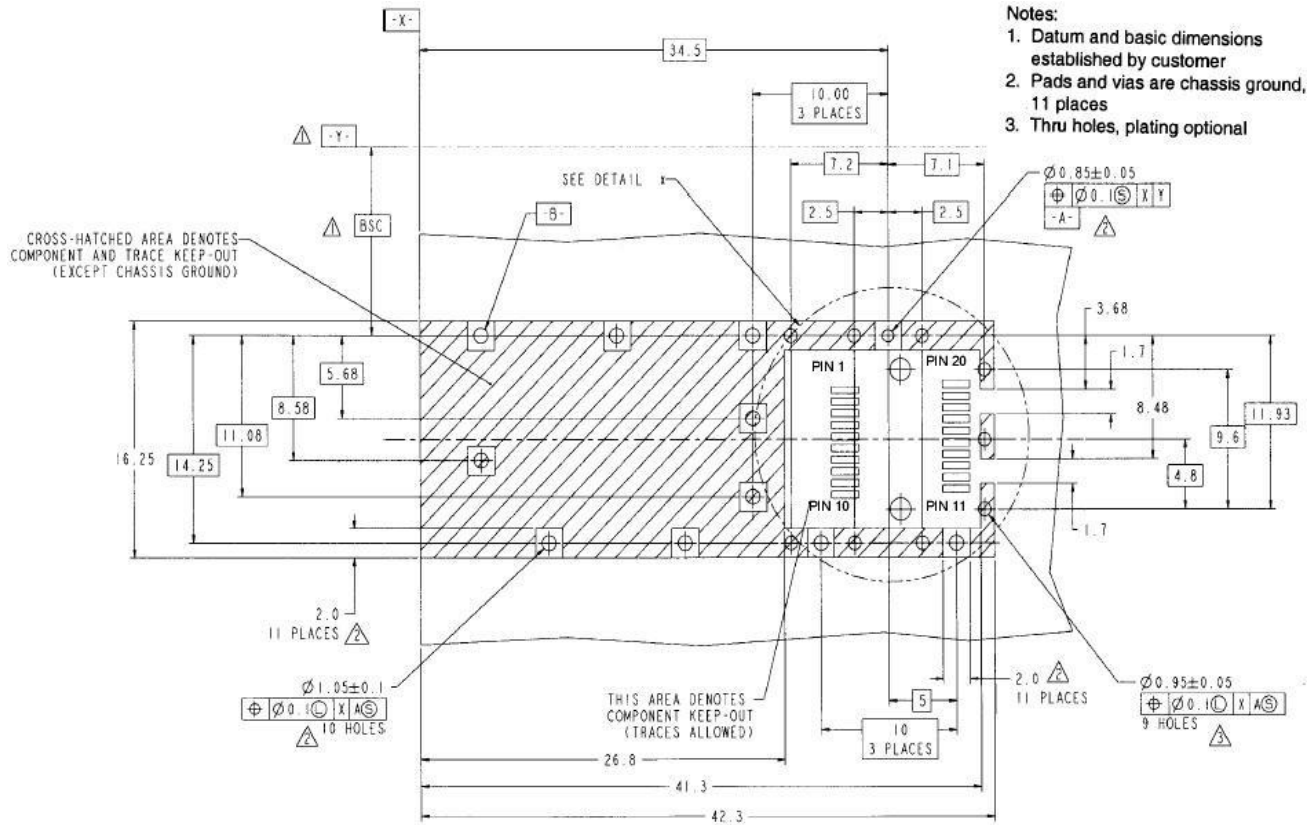

- Notes:**
1. Datum and basic dimensions established by customer
 2. Pads and vias are chassis ground, 11 places
 3. Thru holes, plating optional

Pin Description:

SFP Host Board Mechanical Layout(Cont)

Pin No	Name	Function	Notes
1	VeeT	Transmitter Ground	1
2	TX Fault	Transmitter Fault Indication	
3	TX Disable	Transmitter Disable	2
4	MOD-DEF2	Module Definition	3
5	MOD-DEF1	Module Definition 1	3
6	MOD-DEF0	Module Definition 0	3
7	Rate Select	Not Connected	4
8	LOS	Loss of Signal	5
9	VeeR	Receiver Ground	1
10	VeeR	Receiver Ground	1
11	VeeR	Receiver Ground	1
12	RD-	Inv. Received Data Out	6
13	RD+	Received Data Out	6
14	VeeR	Receiver Ground	1
15	VccR	Receiver Power	1
16	VccT	Transmitter Power	
17	VeeT	Transmitter Ground	
18	TD+	Transmit Data In	6
19	TD-	Inv. Transmit In	6
20	VeeT	Transmitter Ground	

Notes:

1. Circuit ground is internally isolated from chassis ground.
2. Laser output disabled on TDIS >2.0V or open, enabled on TDIS <0.8V.
3. Should be pulled up with 4.7k - 10 kohms on host board to a voltage between 2.0V and 3.6V. MOD_DEF(0) pulls line low to indicate module is plugged in.
4. Rate select is not used
5. LOS is open collector output. Should be pulled up with 4.7k – 10 kohms on host board to a voltage between 2.0V and 3.6V. Logic 0 indicates normal operation; logic 1 indicates loss of signal.
6. AC Coupled

Serial ID Memory Contents:

Data Address	Length (Byte)	Name of Length	Description and Contents
Base ID Fields			
0	1	Identifier	Type of Serial transceiver (03h=SFP)
1	1	Reserved	Extended identifier of type serial transceiver (04h)
2	1	Connector	Code of optical connector type (07=LC)
3-10	8	Transceiver	Gigabit Ethernet 1000Base-ZX & Fiber Channel
11	1	Encoding	8B10B (01h)
12	1	BR,Nominal	Nominal baud rate, unit of 100Mbps
13-14	2	Reserved	(0000h)
15	1	Length(9um)	Link length supported for 9/125um fiber, units of 100m
16	1	Length(50um)	Link length supported for 50/125um fiber, units of 10m
17	1	Length(62.5um)	Link length supported for 62.5/125um fiber, units of 10m
18	1	Length(Copper)	Link length supported for copper, units of meters
19	1	Reserved	
20-35	16	Vendor Name	SFP vendor name
36	1	Reserved	
37-39	3	Vendor OUI	SFP transceiver vendor OUI ID
40-55	16	Vendor PN	Part Number
56-59	4	Vendor rev	Revision level for part number
60-61	2	Wavelength	Laser wavelength
62	1	Reserved	
63	1	CCID	Least significant byte of sum of data in address 0-62
Extended ID Fields			
64-65	2	Option	Indicates which optical SFP signals are implemented (001Ah = LOS, TX_FAULT, TX_DISABLE all supported)
66	1	BR, max	Upper bit rate margin, units of %
67	1	BR, min	Lower bit rate margin, units of %
68-83	16	Vendor SN	Serial number (ASCII)
84-91	8	Date code	Manufacturing date code
92-94	3	Reserved	
95	1	CCEX	Check code for the extended ID Fields (addresses 64 to 94)
Vendor Specific ID Fields			
96-127	32	Readable	Specific date, read only

Recommended Circuit:

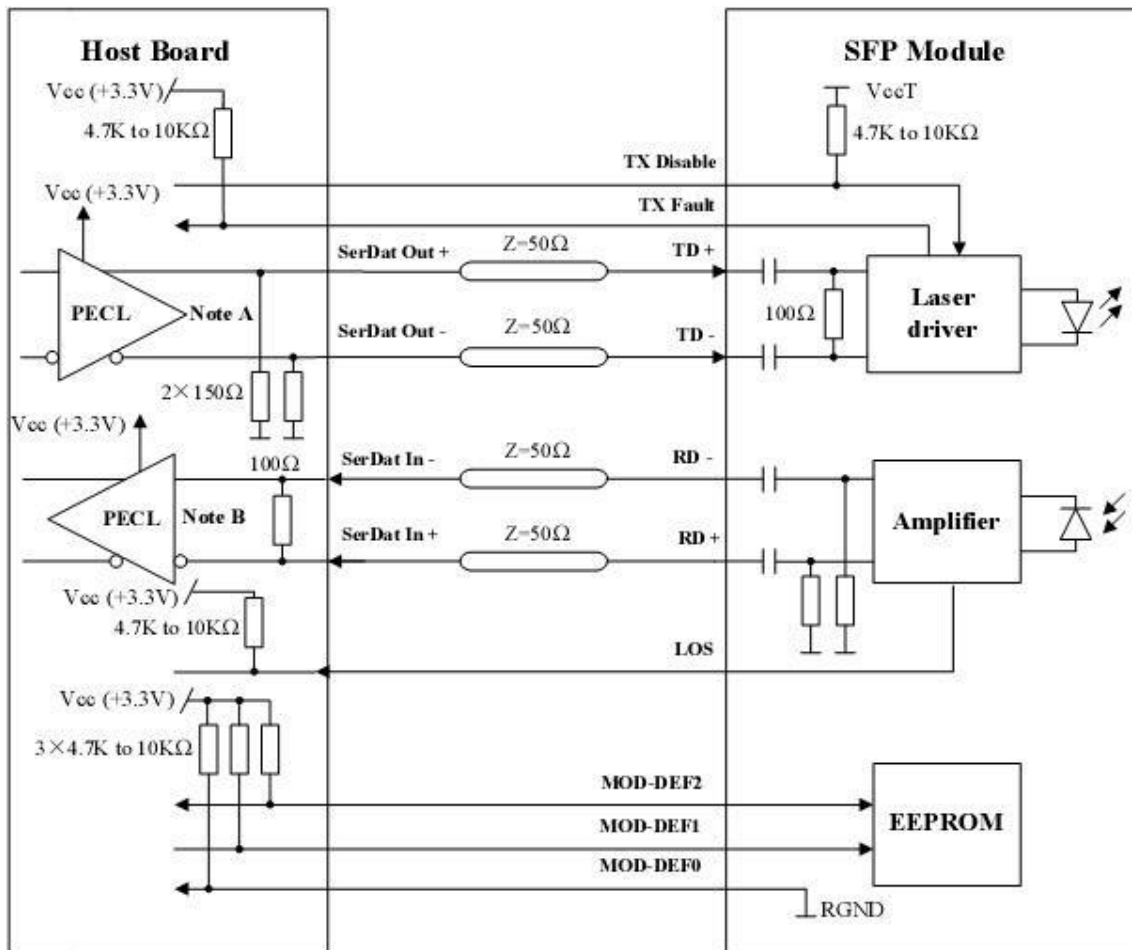

Note A: Circuit assumes open emitter output

Note B: Circuit assumes high impedance internal bias @ Vcc-1.3V

Mechanical Dimensions:

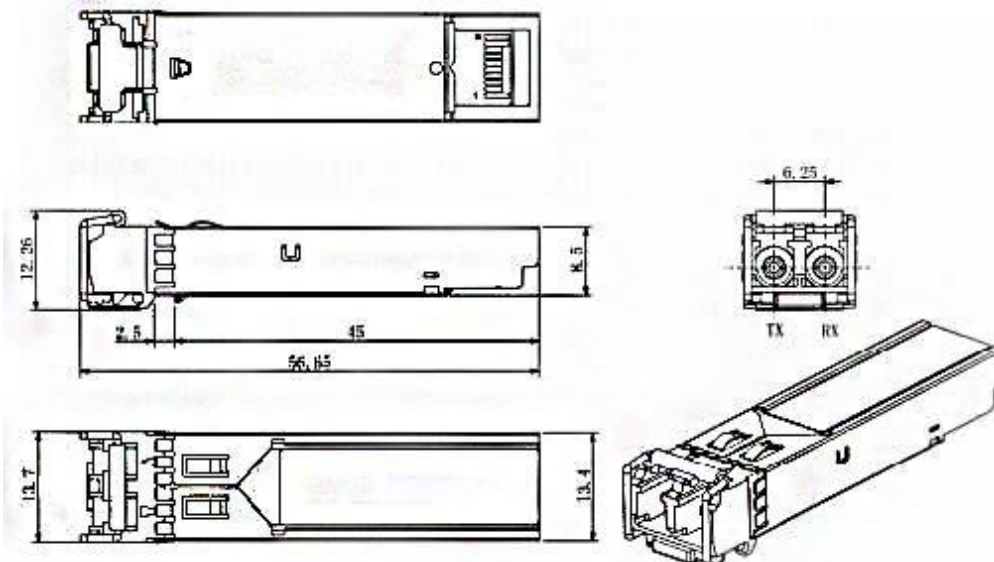

Note: In the Part No. of NPC-xx03-08CD, XX stands for wavelength, such as:
 27: for 1271nm, 29: for 1291nm, 31: for 1311nm, 33: for 1331nm, 35: for 1351nm,
 37: for 1371nm, 39: for 1391nm, 41: for 1411nm, 43: for 1431nm, 45: for 1451nm,
 47: for 1471nm, 49: for 1491nm, 51: for 1511nm, 53: for 1531nm, 55: for 1551nm,
 57: for 1571nm, 59: for 1591nm, 61: for 1611nm.